



INDEX	
SHEET NO.	SUBJECT
1	Drawing Index and General Notes
2	Class I Drive (Residential) Plan
3	Class II Drive (Residential) Plan
4	Class III Drive (Commercial) Plan
5	Class IV Drive (Commercial) Plan
6	Class V Drive (Field Entrance) Plan and Section
7	Class VI Drive (Industrial) Plan and Section
8	Class VII Drive (Industrial) Plan
9	Class I and Class III Drives Approach Grades
10	Class II and Class IV Drives Sections
11	Class II, IV & V Drives Approach Grades
12	Class VI Drive Approach Grades
13	Class VII Drive Approach Grades
14	Joint Placement, Corner Reinforcing, Monolithic Curb, and Concrete Curb and Gutter Details
15	Private Drive Crossover Plans
16	Private and Commercial Drive Crossover Sections
17	Commerical Drive Crossover Plans
18	Pavement Wedge and Pay Limits for Class II, IV and VII Drives

GENERAL NOTES

1. When the maximum approach grade of $\pm 10\%$ does not meet the grade of the existing drive before the R/W line, the approach grade of $\pm 10\%$ shall extend beyond the R/W to the point of intersection with the existing driveway grade. Construction beyond the R/W line shall be done in temporary R/W.
2. The appropriate pipe end treatment should be provided for pipes located either inside the clear zone or outside the clear zone.
3. The minimum driveway pavement sections for Class III, IV, VI and VII Drives have been designed for 400 trucks per day. If the truck traffic count is greater than 400 per day, the required pavement section shall be as shown elsewhere on the plans.
4. For Class III, IV, VI and VII Drives, if length of the driveway is more than 15 feet, then D-1 contraction joints are required in transverse direction. Spacing shall be 1/2 the length of the driveway or 15 feet max.
5. Embankment slopes within the mainline clear zone for new construction/reconstruction projects or within the obstruction-free zone for 3R projects should be as shown in the table on Standard Drawing E 610-PRAP-01. Outside the clear zone or the obstruction-free zone, the embankment slopes should desirably be 4:1 but not steeper than 3:1.

INDIANA DEPARTMENT OF TRANSPORTATION	
INDEX GENERAL NOTES AND LEGEND SEPTEMBER 2019	
STANDARD DRAWING NO. E 610-DRIV-01	
	 DESIGN STANDARDS ENGINEER 5/1/2019 <small>DATE</small>
	 CHIEF ENGINEER 6/5/2019 <small>DATE</small>

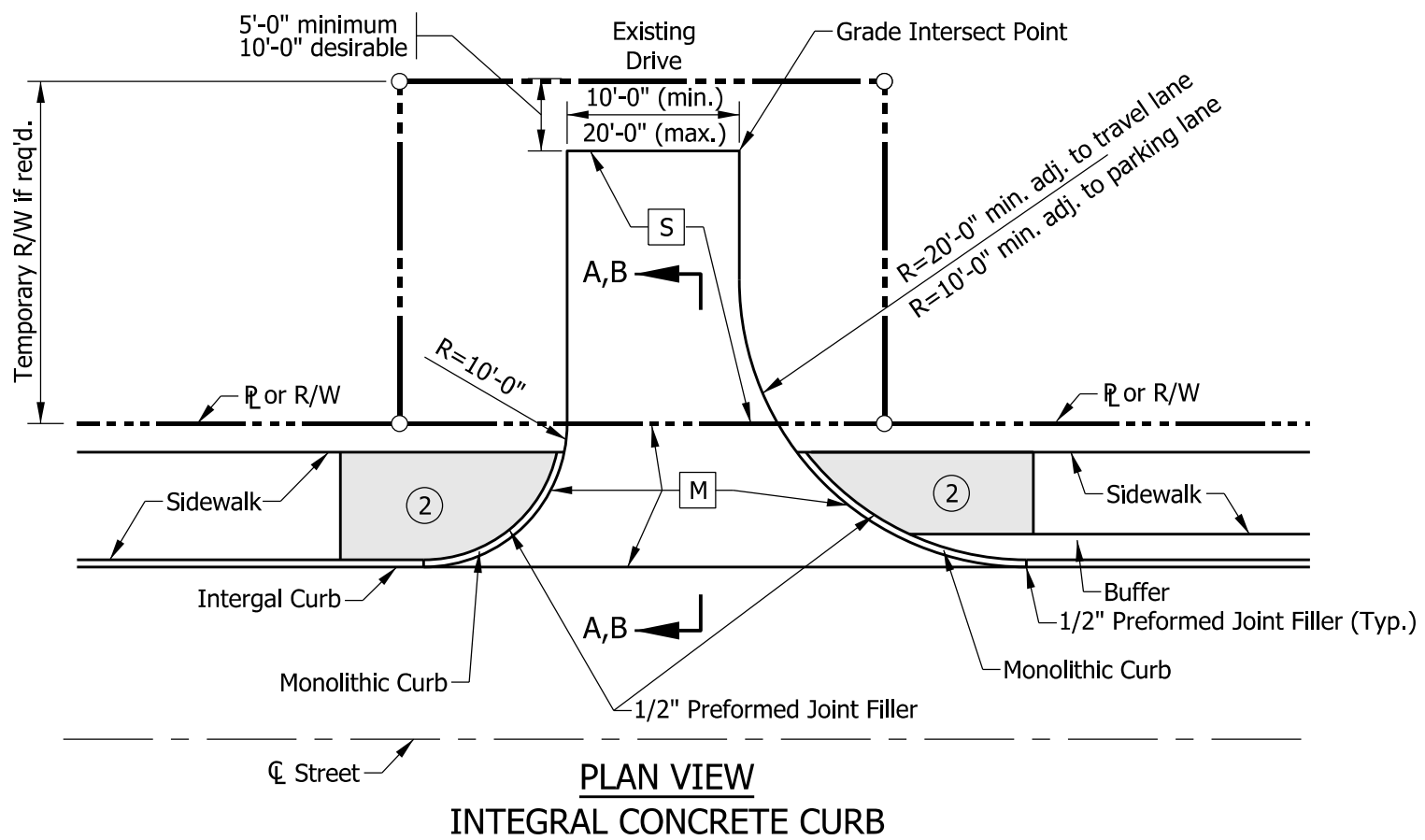
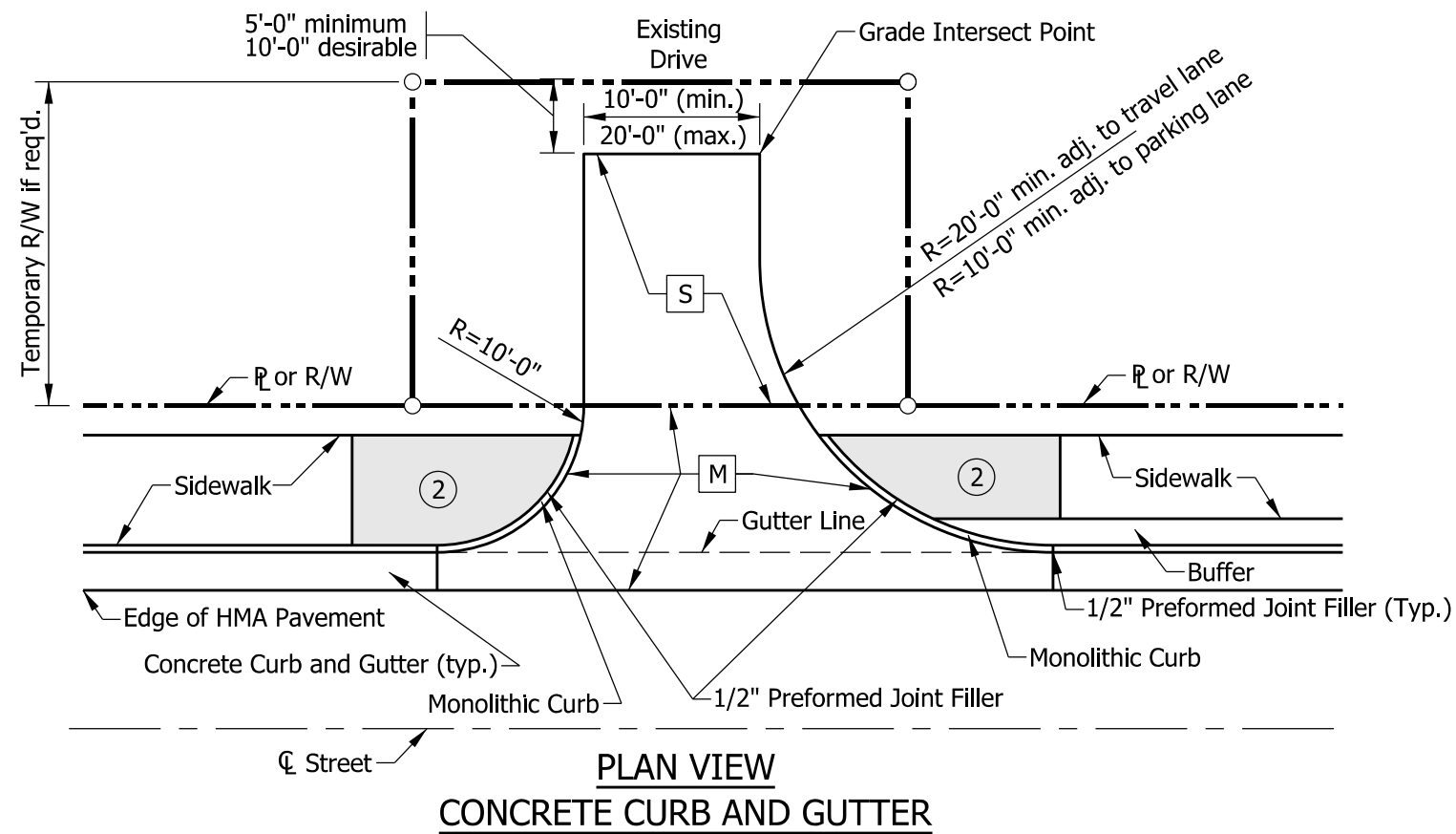



NOTES:

1. See Standard Drawing series E 610-DRIV-14 for joint placement, corner reinforcing, monolithic curb, and concrete curb and gutter details.
- ② See Standard Drawing E 604-SDWK-03 sidewalk driveway crossing details.
3. See Standard Drawing E 610-DRIV-09 for Sections A-A and B-B.

LEGEND

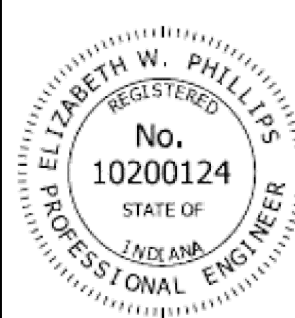
- M PCCP for Approaches, 6 in., on Dense Graded Subbase, 6 in., on Subgrade Treatment Type II (6 in. Coarse Aggregate No. 53)
- S For type and thickness equivalent to surface in place, see plans.
- Sidewalk Elevation Transition

INDIANA DEPARTMENT OF TRANSPORTATION	
CLASS I DRIVE (RESIDENTIAL)	
SEPTEMBER 2019	
STANDARD DRAWING NO. E 610-DRIV-02	
	<div style="text-align: right;">  5/1/2019 DESIGN STANDARDS ENGINEER DATE </div> <div style="text-align: right;">  6/5/2019 CHIEF ENGINEER DATE </div>

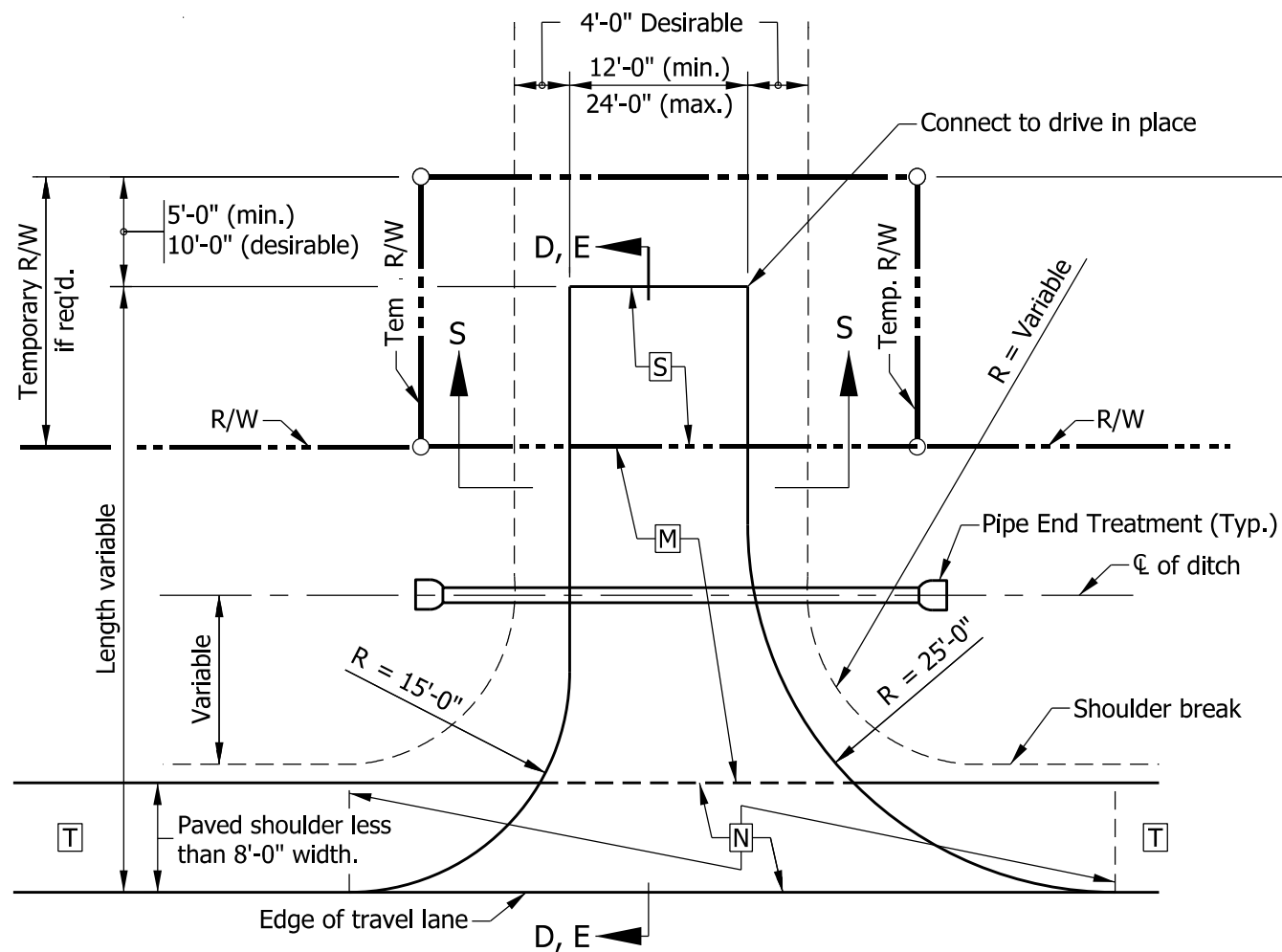

PLAN VIEW

(PAVED SHOULDER LESS THAN 8'-0" IN WIDTH OR UNPAVED SHOULDER)

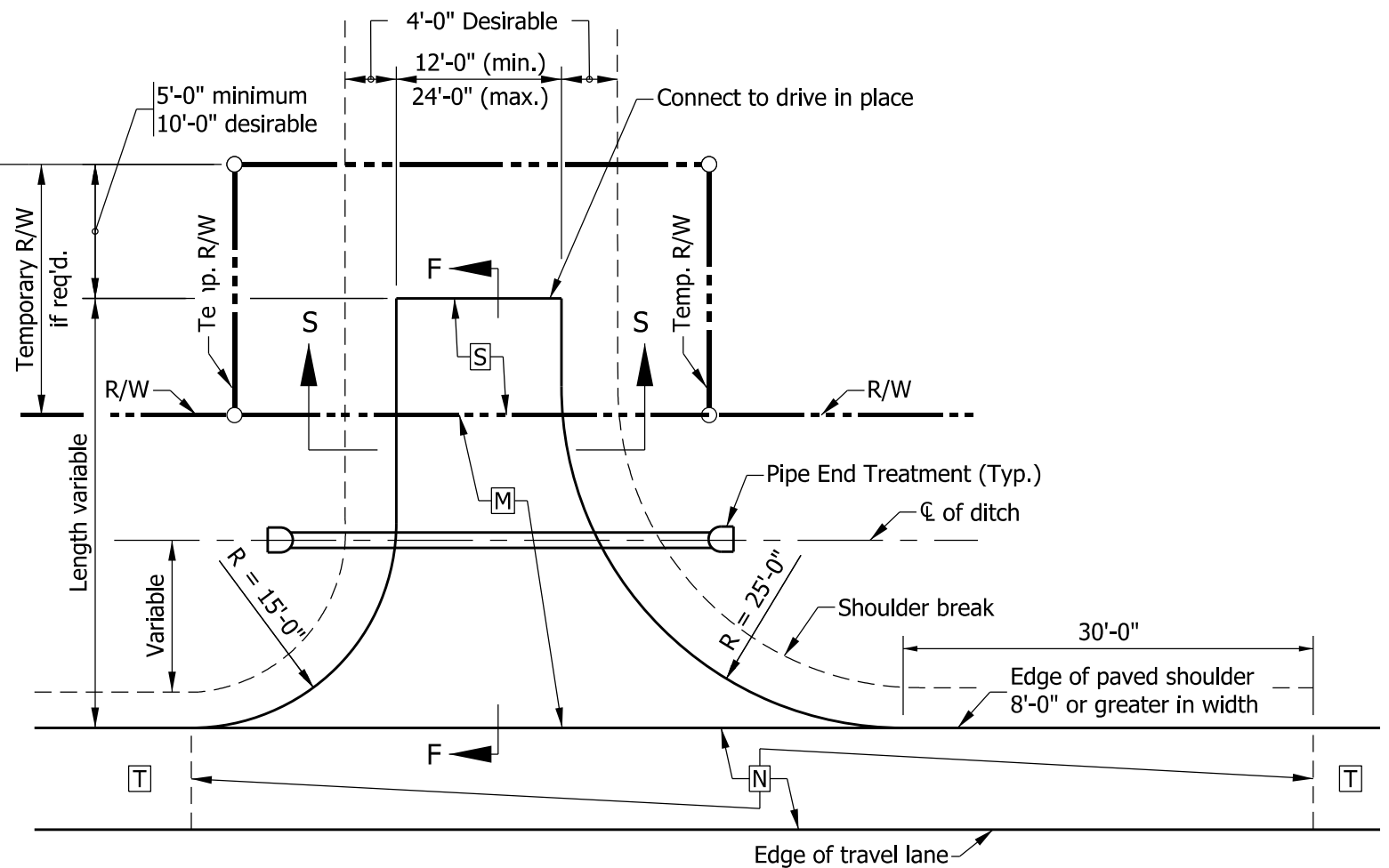

PLAN VIEW

(PAVED SHOULDER 8'-0" OR GREATER IN WIDTH)

LEGEND

- [M] HMA for Approaches, Type B
165#/syd HMA Surface Type B on
275#/syd HMA Intermediate Type B on
6" Compacted Aggregate No. 53, on
Subgrade Treatment Type II (6 in. Coarse Aggregate No. 53)
or
PCCP for Approaches, 6 in., on
Dense Graded Subbase, 6 in., on
Subgrade Treatment Type II (6 in. Coarse Aggregate No. 53)
- [N] The greater thickness of either the drive [M]
or the paved shoulder [T] section.
- [S] For type and thickness equivalent
to surface in place, see plans.
- [T] Plan shoulder section.

NOTES:

1. See Standard Drawing E 610-DRIV-10 for Section S-S.
2. See Standard Drawing E 610-DRIV-11 for Sections D-D, E-E and F-F for approach grades.
3. The radii for PCCP Class II drives shall be constructed using corner reinforcement as detailed in Standard Drawing E 610-DRIV-14.
4. For PCCP Drives see Standard Drawing E 610-DRIV-14 for joint placement details.

INDIANA DEPARTMENT OF TRANSPORTATION

CLASS II DRIVE
(RESIDENTIAL)

SEPTEMBER 2019

STANDARD DRAWING NO. E 610-DRIV-03

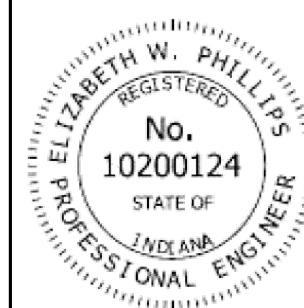

Elizabeth W. Phillips
DESIGN STANDARDS ENGINEER

5/1/2019

DATE

[Signature]
CHIEF ENGINEER

6/5/2019

DATE

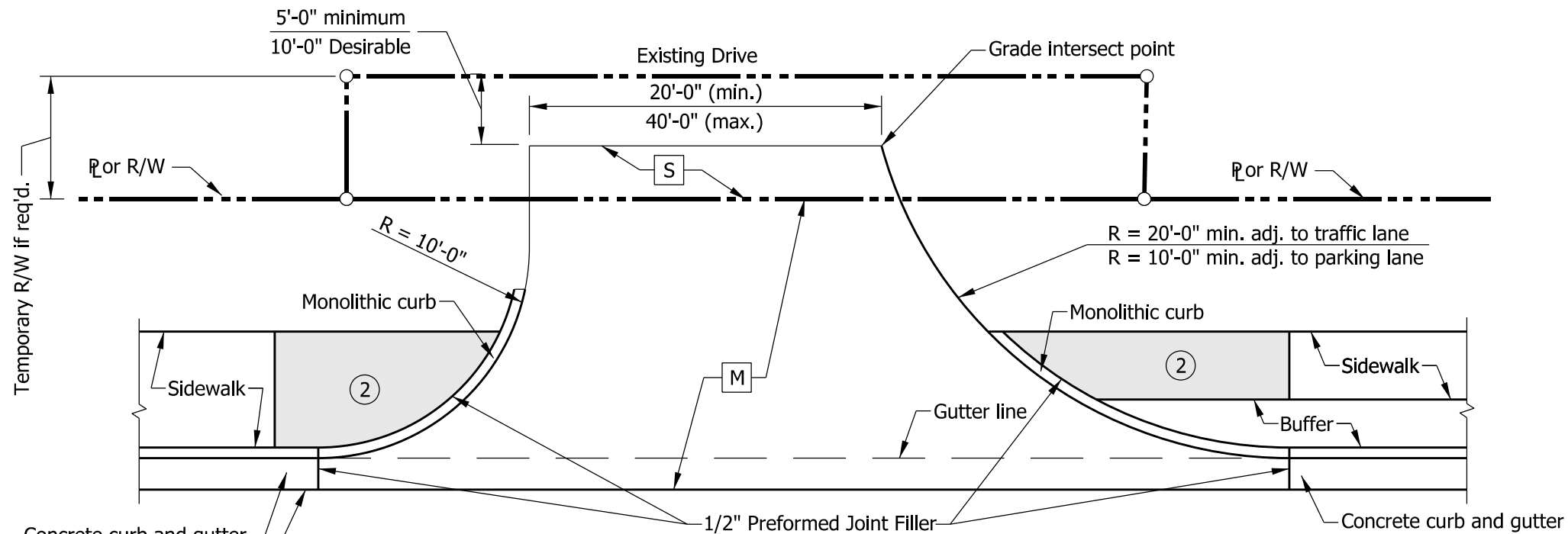

**PLAN VIEW
CONCRETE CURB AND GUTTER**

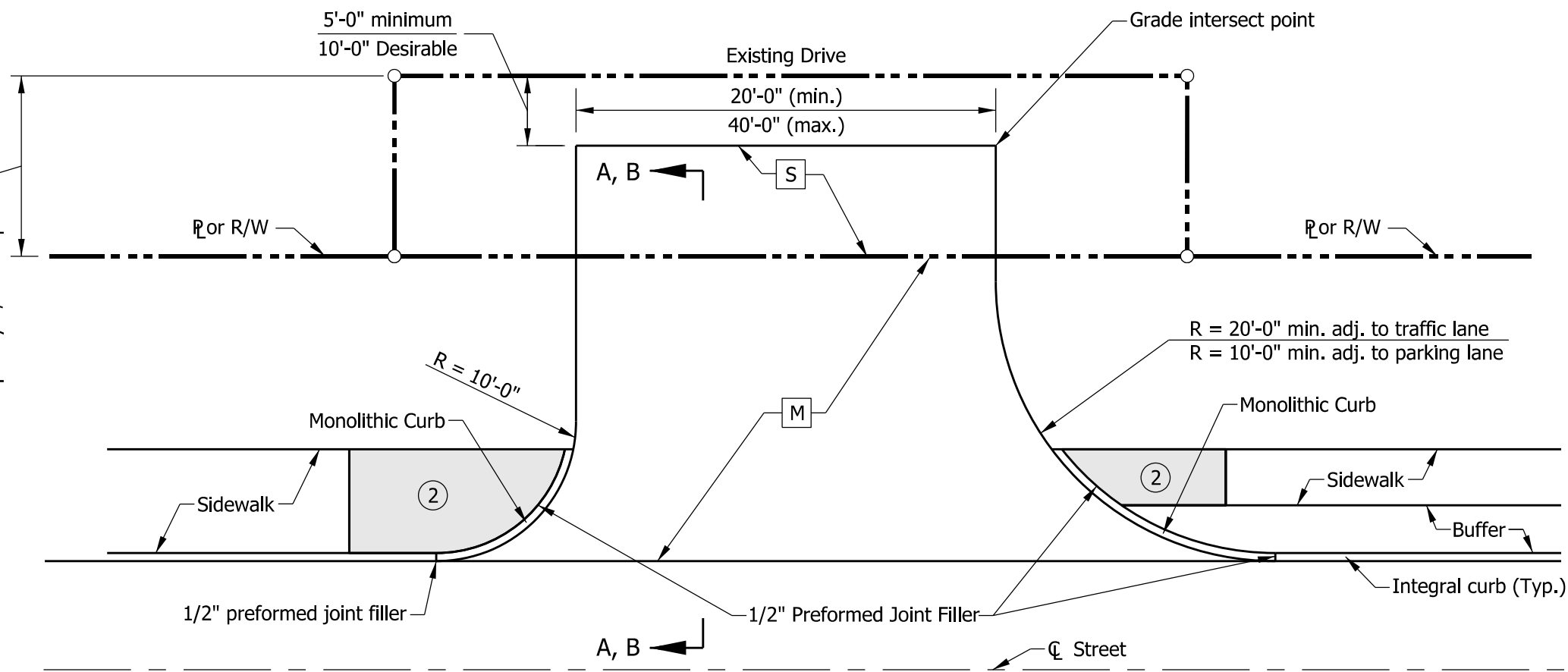

**PLAN VIEW
INTEGRAL CONCRETE CURB**

NOTES:

1. See Standard Drawing E 610-DRIV-09 for Section A-A, and Section B-B.
- ② See Standard Drawing E 604-SDWK-03 for sidewalk driveway crossing details.
3. See Standard Drawing E 610-DRIV-14 for joint placement, monolithic curb, and concrete curb and gutter details.

LEGEND

- M** PCCP for Approaches, 9 in., on Dense Graded Subbase, 6 in., on Geogrid Type 1B, on Subgrade Treatment Type II (6 in. Coarse Aggregate No. 53)
- S** For type and thickness equivalent to surface in place, see plans.
- ② Sidewalk elevation transitions.

INDIANA DEPARTMENT OF TRANSPORTATION

CLASS III DRIVE
(COMMERCIAL)

SEPTEMBER 2019

STANDARD DRAWING NO. E 610-DRIV-04

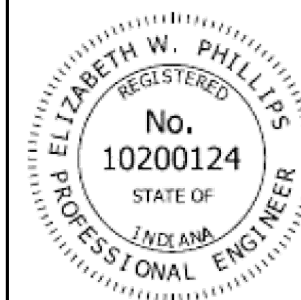

Elizabeth W. Phillips
DESIGN STANDARDS ENGINEER

5/1/2019
DATE

[Signature]
CHIEF ENGINEER

6/5/2019
DATE

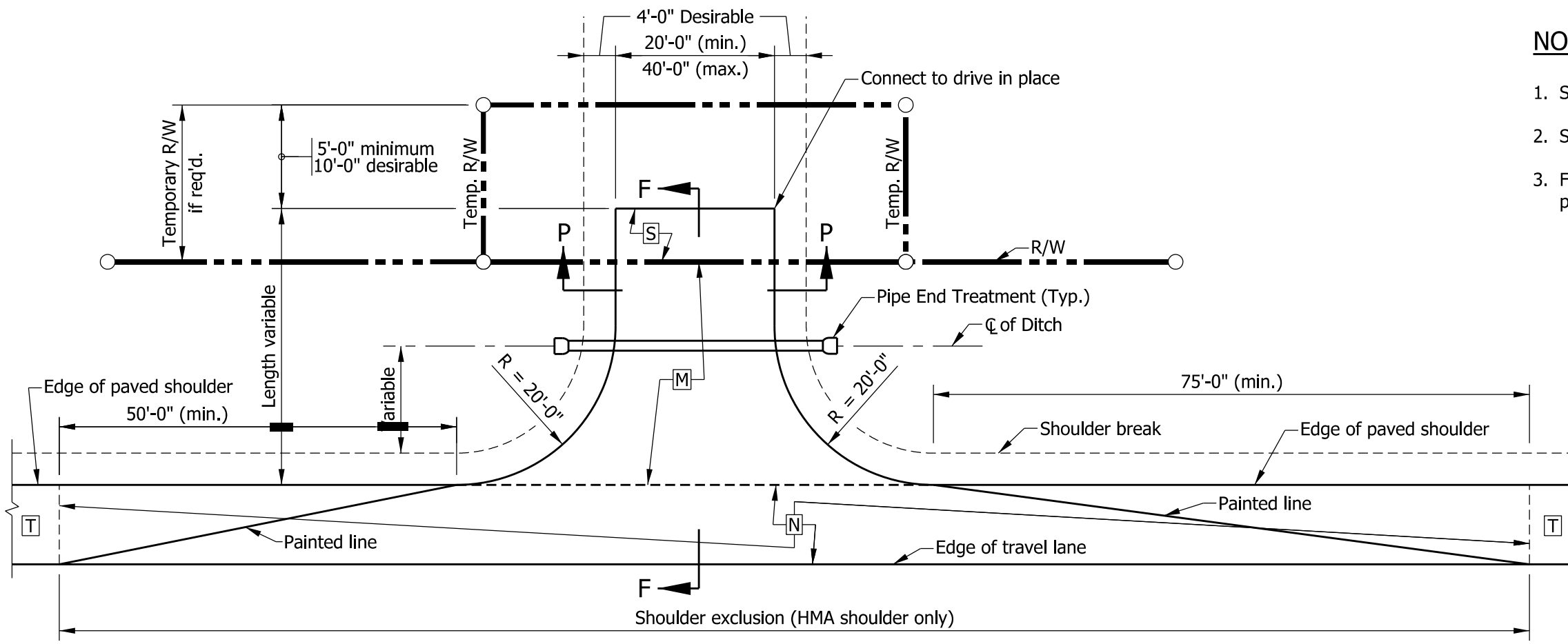

PLAN VIEW
(PAVED SHOULDER 8'-0" FEET OR GREATER IN WIDTH)

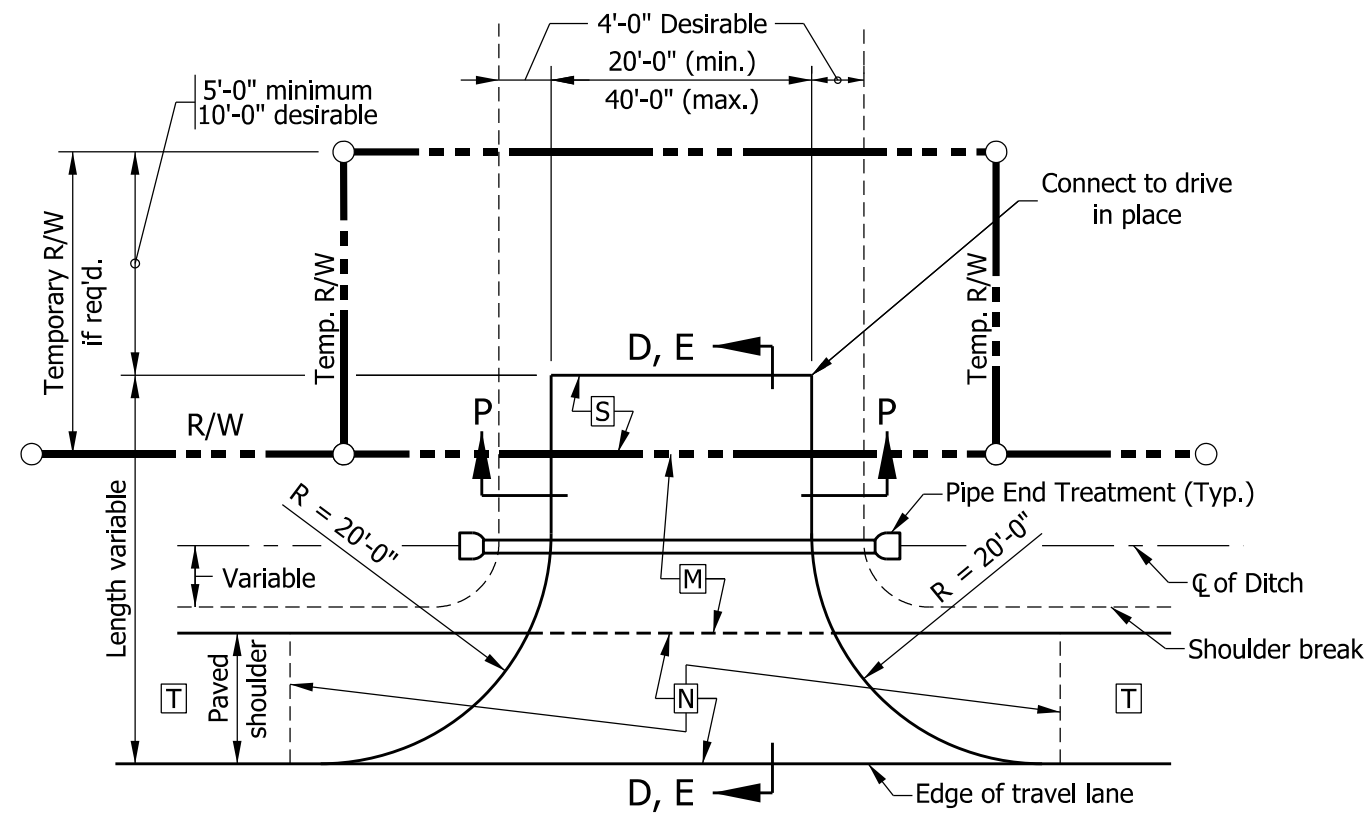

PLAN VIEW
(PAVED SHOULDER LESS THAN 8'-0" IN WIDTH OR UNPAVED SHOULDER)

NOTES:

1. See Standard Drawing E 610-DRIV-11 for Sections D-D, E-E and F-F.
2. See Standard Drawing E 610-DRIV-10 for Section P-P.
3. For PCCP Drives, see Standard Drawing E 610-DRIV-14 for joint placement details.

LEGEND

- M** HMA for Approaches, Type B, 165 lbs/syd HMA Surface, Type B, on 275 lbs/syd HMA Intermediate, Type B, on 660 lbs/syd HMA Base, Type B, on Subgrade Treatment Type II (6 in. Coarse Aggregate No. 53), on Geogrid, Type 1B
or
PCCP for Approaches, 9 in., on Dense Graded Subbase, 6 in., on Geogrid Type 1B on Subgrade Treatment Type II (6 in. Coarse Aggregate No. 53)
- N** The greater thickness of either the drive **M** or the paved shoulder **T** section.
- S** For type and thickness equivalent to surface in place, see plans.
- T** Plan shoulder section.

INDIANA DEPARTMENT OF TRANSPORTATION

CLASS IV DRIVE
(COMMERCIAL)

SEPTEMBER 2019

STANDARD DRAWING NO. E 610-DRIV-05

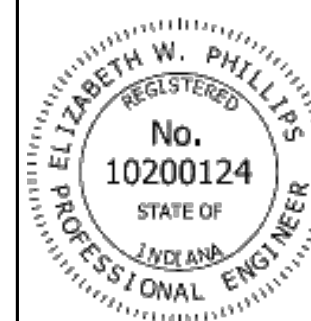

Elizabeth W. Phillips
DESIGN STANDARDS ENGINEER 5/29/2019
DATE

[Signature]
CHIEF ENGINEER 6/5/2019
DATE

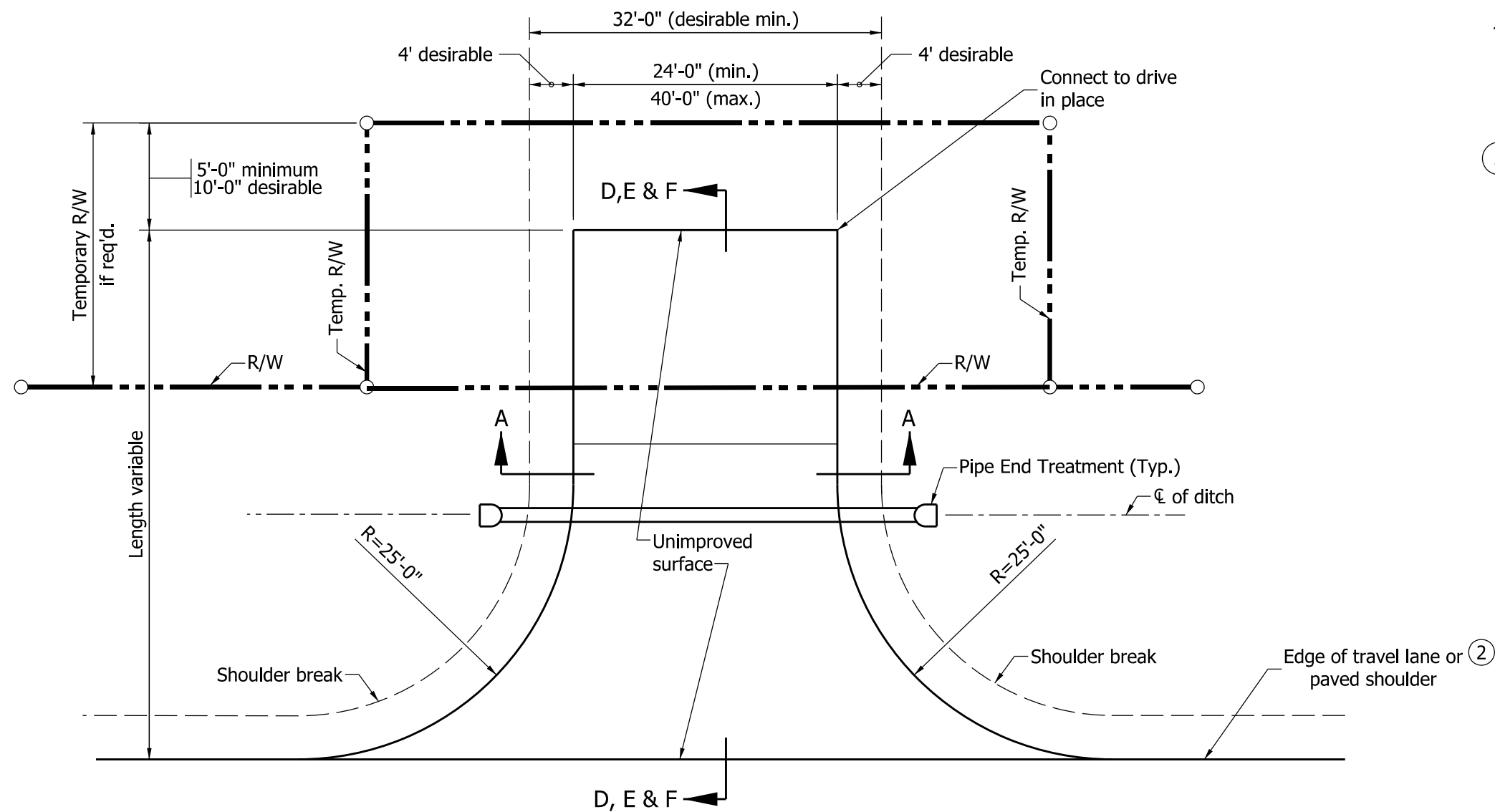

PLAN VIEW

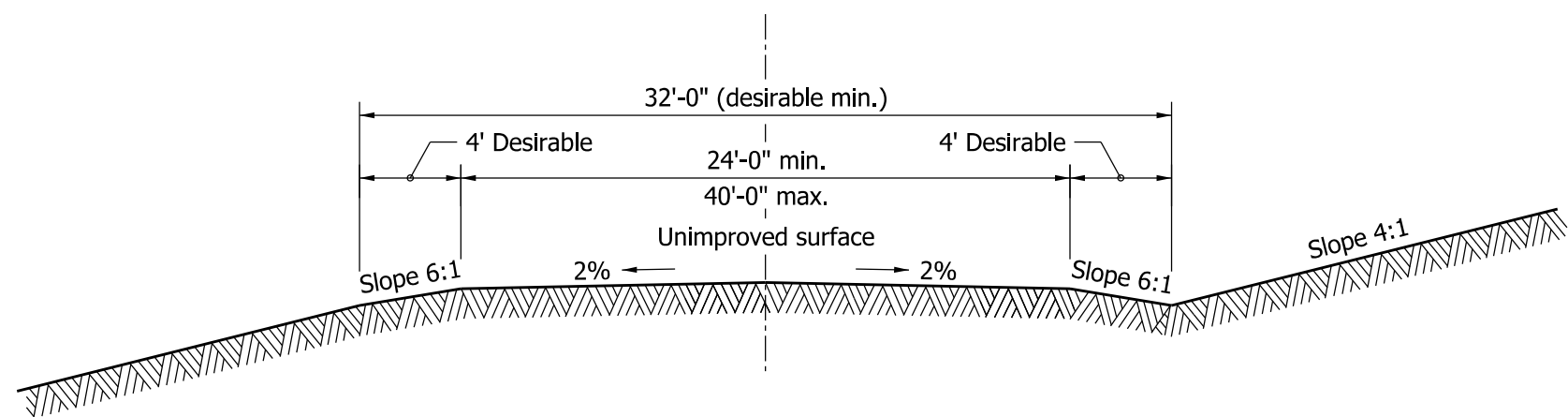

SECTION A-A

NOTES:

1. See Standard Drawing E 610-DRIV-11 for sections D-D, E-E, and F-F.
2. Where the shoulder is earth or aggregate or the paved width is less than 8'-0", the drive radii shall be tangent to the edge of the travel lane. Where the paved shoulder width is 8'-0" or more, the drive radii shall be tangent to the edge of the paved shoulder.

INDIANA DEPARTMENT OF TRANSPORTATION

CLASS V DRIVE
(FIELD ENTRANCE)

SEPTEMBER 2019

STANDARD DRAWING NO. E 610-DRIV-06

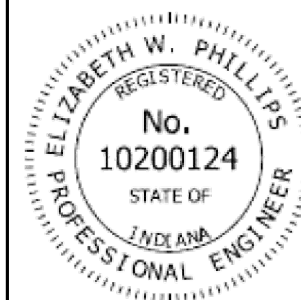

Elizabeth W. Phillips
DESIGN STANDARDS ENGINEER

5/1/2019
DATE

[Signature]
CHIEF ENGINEER

6/5/2019
DATE

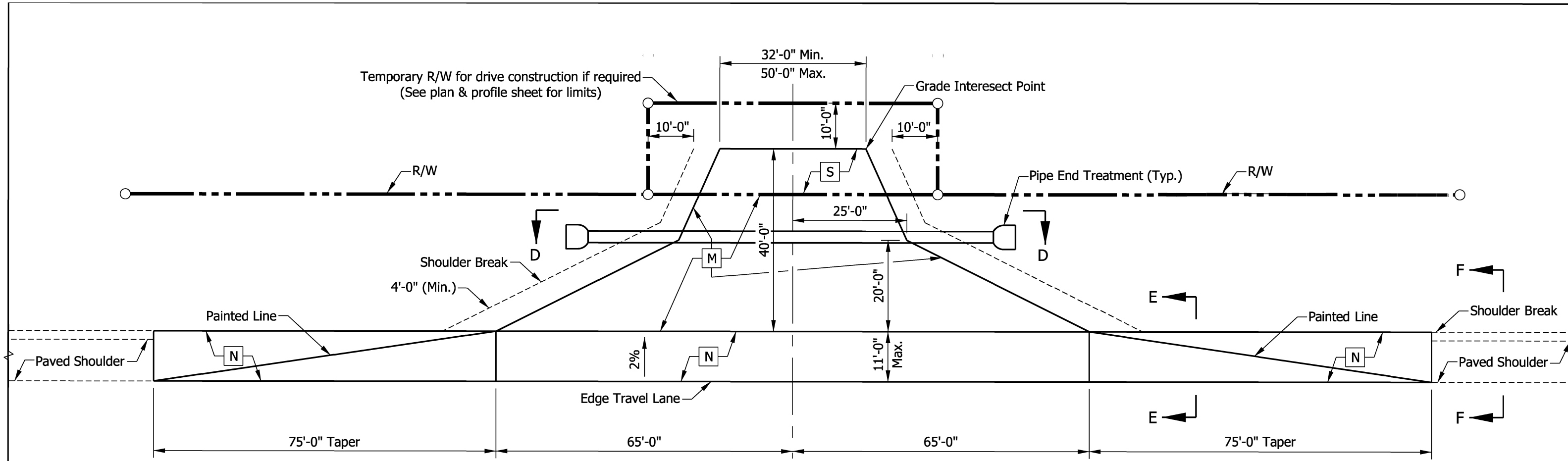

PLAN VIEW

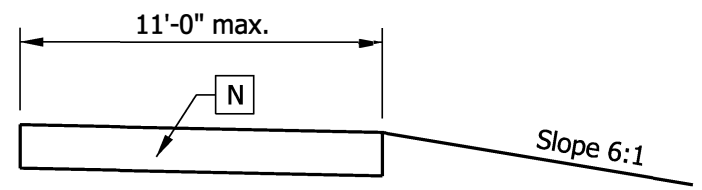

SECTION E-E

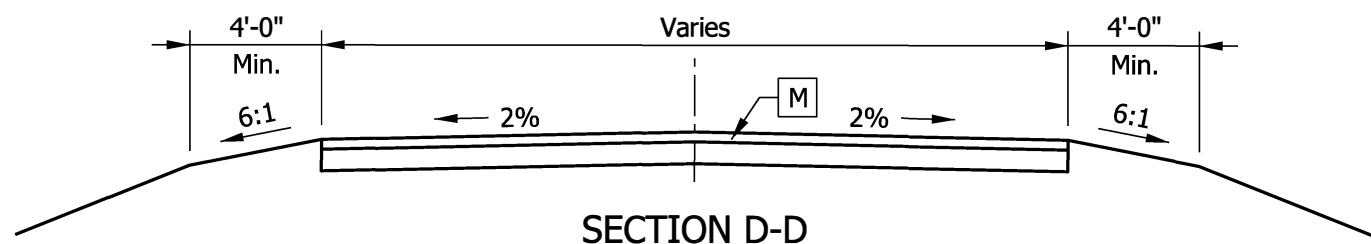

SECTION D-D

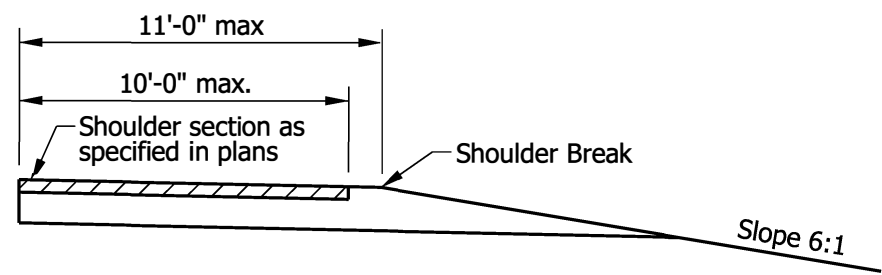

SECTION F-F

LEGEND

- M** For ≤ 400 Trucks per day
HMA for Approaches, Type B,
165 lbs/syd HMA Surface, Type B, on
275 lbs/syd HMA Intermediate, Type B on
660 lbs/syd HMA Base, Type B on
Subgrade Treatment Type II (6 in. Coarse Aggregate No.53), on
Geogrid, Type 1B
or
PCCP for Approaches, 9 in., on
Dense Graded Subbase, 6 in., on
Geogrid, Type 1B, on
Subgrade Treatment Type II (6 in. Coarse Aggregate No.53)
- N** The greater thickness of either the drive **M**
or the paved shoulder section.
- S** For type and thickness equivalent
to surface in place, see plans.

NOTES:

1. See Standard Drawing E 610-DRIV-12 for drive approach grades.
2. Class VI Drive accommodates a WB-67 (IDV) design vehicle with a 45'-0" turning radius.
3. For PCCP Drives see Standard Drawing E 610-DRIV-14 for joint placement details.

INDIANA DEPARTMENT OF TRANSPORTATION	
CLASS VI DRIVE (INDUSTRIAL)	
SEPTEMBER 2019	
STANDARD DRAWING NO. E 610-DRIV-07	
	 DESIGN STANDARDS ENGINEER 5/1/2019 DATE
 CHIEF ENGINEER 6/5/2019 DATE	

NOTES:

1. See Standard Drawing E 610-DRIV-02 Class I Drive pavement section.
2. See Standard Drawing E 610-DRIV-04 Class III Drive pavement section.
3. See Standard Drawing E 604-SDWK-03 for sidewalk driveway crossing details.
- ④ The maximum algebraic difference in grades shall not exceed 8% for crested grade nor 12% for sagged grade
- ⑤ See Standard Drawing E 610-DRIV-14 joint placement, monolithic curb, and concrete curb and gutter details.

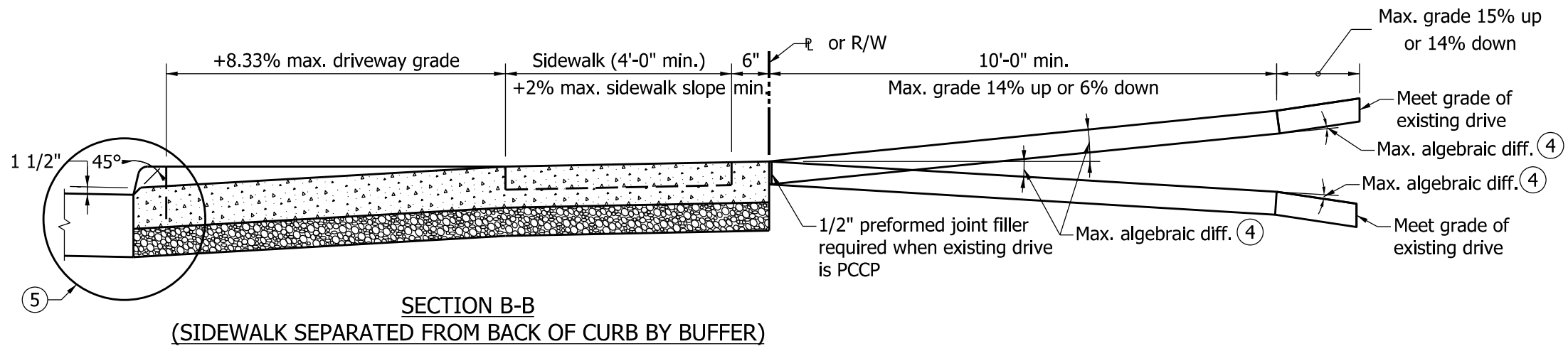
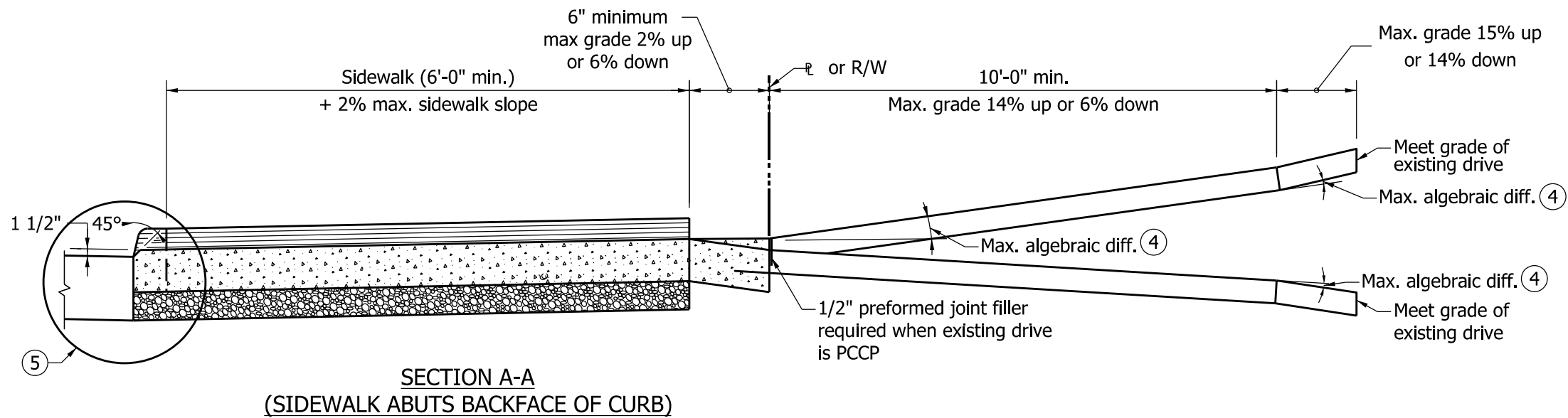

LEGEND

- = Curb ramp or sidewalk elevation transition.
- = PCCP

INDIANA DEPARTMENT OF TRANSPORTATION

CLASS I AND CLASS III DRIVE
APPROACH GRADES

SEPTEMBER 2019

STANDARD DRAWING NO. E 610-DRIV-09

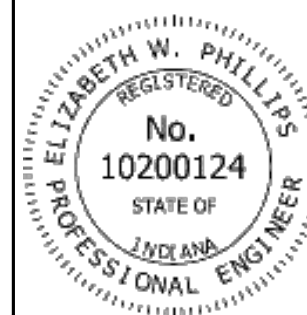

	5/29/2019
DESIGN STANDARDS ENGINEER	DATE
	6/5/2019
CHIEF ENGINEER	DATE

NOTES:

1. See Standard Drawing E 610-DRIV-03 for Class II Drive details.
2. See Standard Drawing E 610-DRIV-05 for Class IV Drive details.

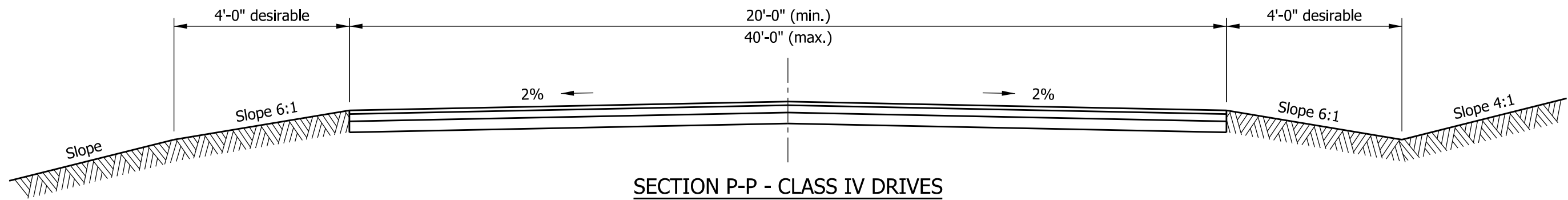

SECTION P-P - CLASS IV DRIVES

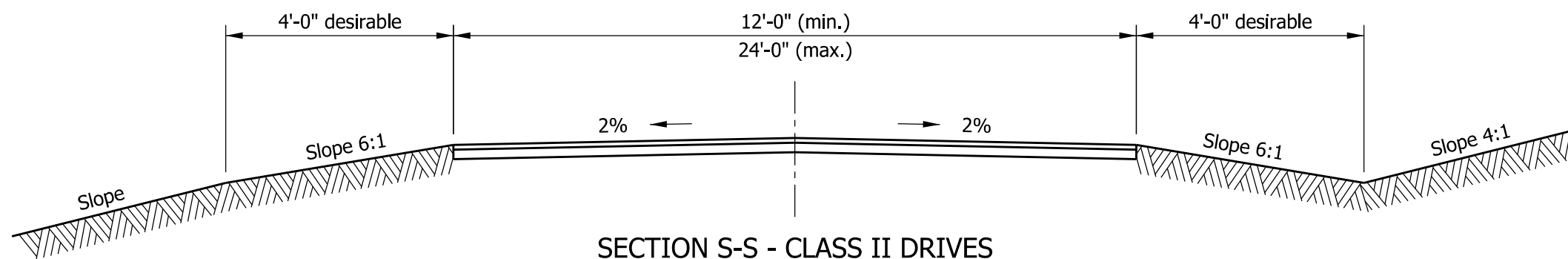

SECTION S-S - CLASS II DRIVES



INDIANA DEPARTMENT OF TRANSPORTATION

CLASS II AND CLASS IV DRIVE SECTIONS

SEPTEMBER 2019

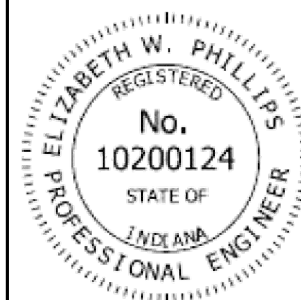
STANDARD DRAWING NO. E 610-DRIV-10



	5/1/2019
DESIGN STANDARDS ENGINEER	DATE
	6/5/2019
CHIEF ENGINEER	DATE

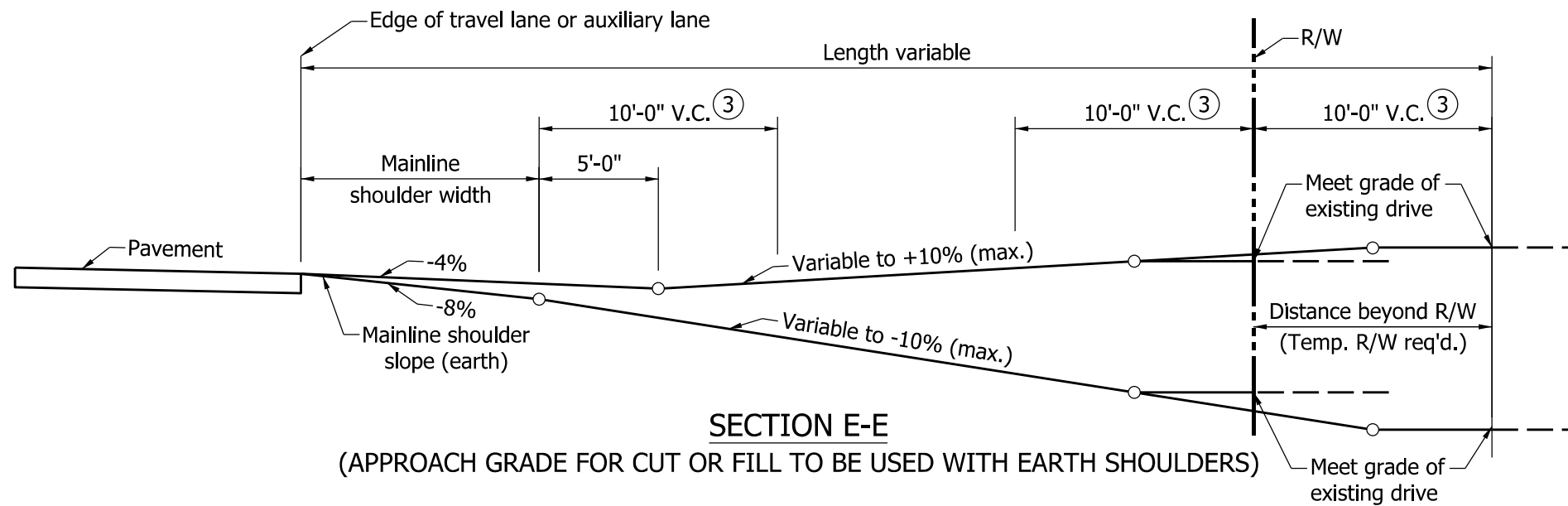

SECTION E-E
(APPROACH GRADE FOR CUT OR FILL TO BE USED WITH EARTH SHOULDERS)

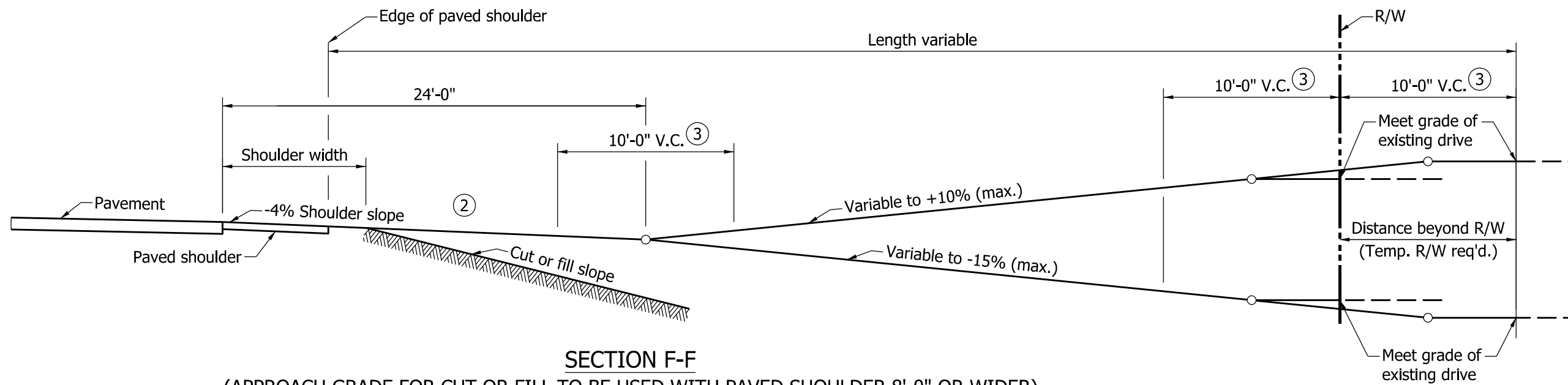

SECTION F-F
(APPROACH GRADE FOR CUT OR FILL TO BE USED WITH PAVED SHOULDER 8'-0" OR WIDER)

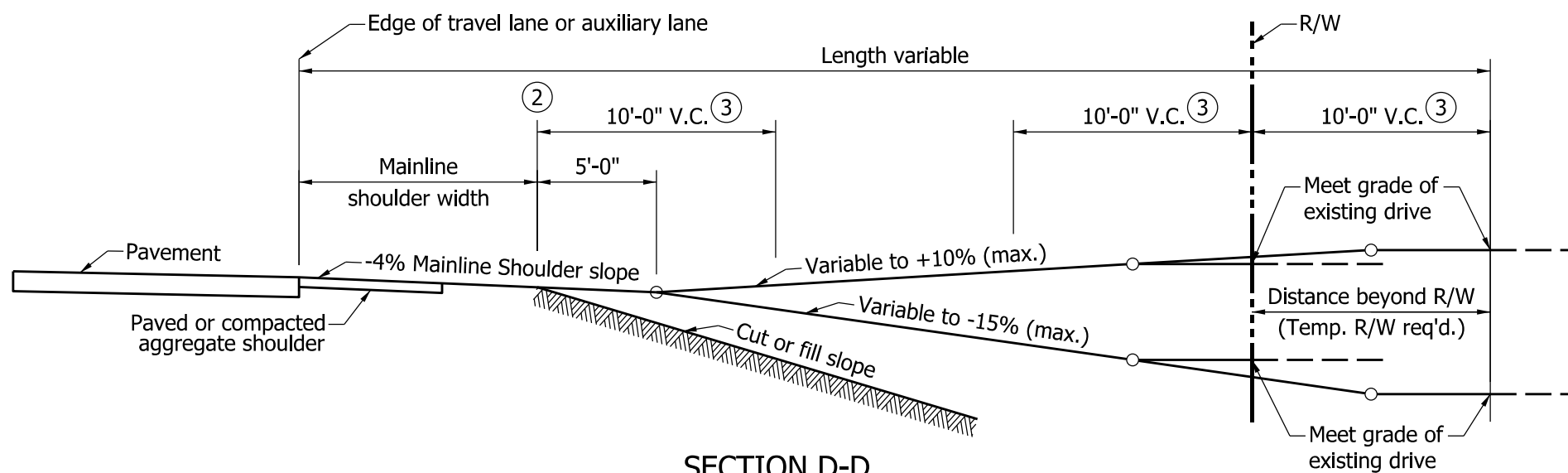

SECTION D-D
(APPROACH GRADE FOR CUT OR FILL TO BE USED WITH LESS THAN 8'-0" WIDTH PAVED OR COMPACTED AGGREGATE SHOULDERS)

NOTES:

1. See Standard Drawing E 610-DRIV-03, -05 and -06 for location of Sections D-D, E-E and F-F.
- ② Where physical restrictions limits the space available for the construction of a drive from a roadway in an embankment section, the downgrade breakpoint of the drive may begin at the edge of the shoulder without a crest vertical curve. The algebraic difference in grades shall not exceed 11%.
- ③ The maximum algebraic difference shall not exceed 11% for crested grade and 14% for sagged grades.

INDIANA DEPARTMENT OF TRANSPORTATION

CLASS II, IV & V DRIVES
APPROACH GRADES

SEPTEMBER 2019

STANDARD DRAWING NO. E 610-DRIV-11

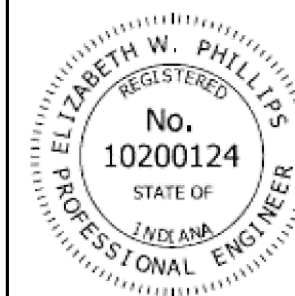

Elizabeth W. Phillips
DESIGN STANDARDS ENGINEER

5/1/2019

DATE

[Signature]
CHIEF ENGINEER

6/5/2019

DATE

NOTES:



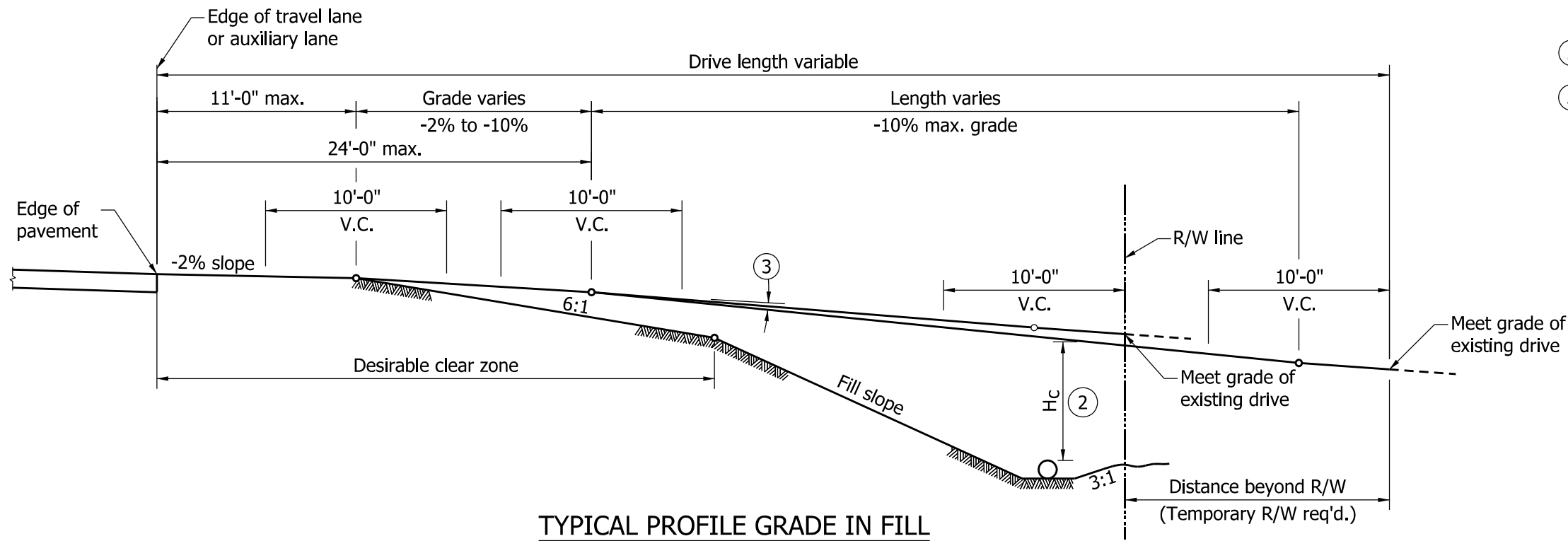

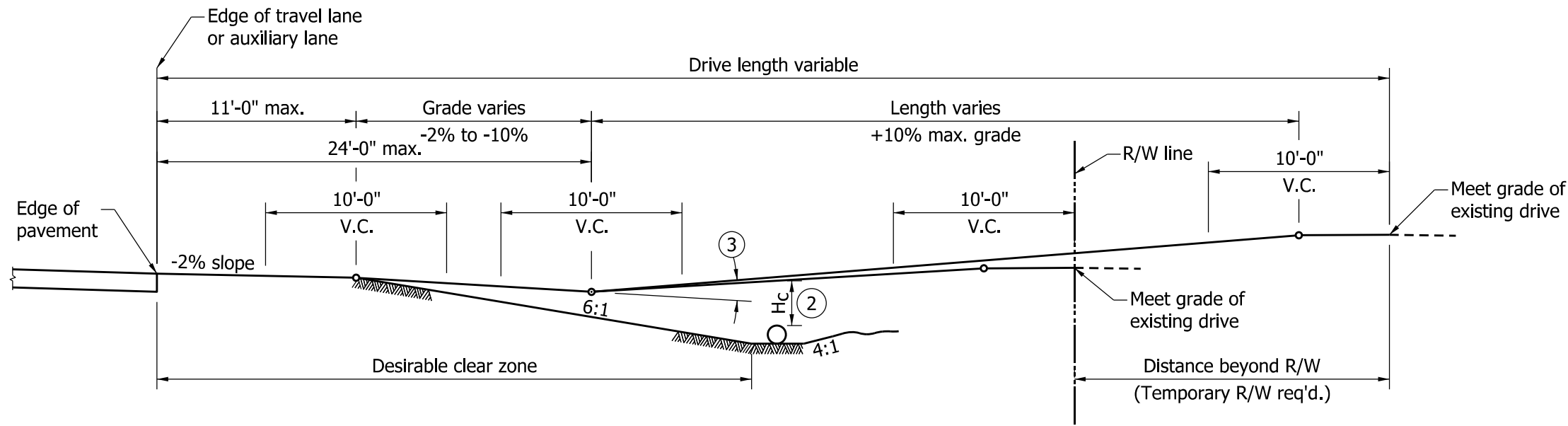

1. See Standard Drawing E 610-DRIV-07 for plan and sections of Class VI Drive.
- ② The earth cover shall be 1 ft or greater.
- ③ The maximum algebraic difference in grades shall not exceed 11% for crested grade and 14% for sagged grades.



TYPICAL PROFILE GRADE IN FILL



TYPICAL PROFILE GRADE IN CUT

INDIANA DEPARTMENT OF TRANSPORTATION									
CLASS VI DRIVE APPROACH GRADES									
SEPTEMBER 2019									
STANDARD DRAWING NO. E 610-DRIV-12									
	<table style="width: 100%; border-collapse: collapse;"> <tr> <td style="text-align: center; padding: 5px;"></td> <td style="text-align: right; padding: 5px;">5/1/2019</td> </tr> <tr> <td style="text-align: center; padding: 5px;">DESIGN STANDARDS ENGINEER</td> <td style="text-align: right; padding: 5px;">DATE</td> </tr> <tr> <td style="text-align: center; padding: 5px;"></td> <td style="text-align: right; padding: 5px;">6/5/2019</td> </tr> <tr> <td style="text-align: center; padding: 5px;">CHIEF ENGINEER</td> <td style="text-align: right; padding: 5px;">DATE</td> </tr> </table>		5/1/2019	DESIGN STANDARDS ENGINEER	DATE		6/5/2019	CHIEF ENGINEER	DATE
	5/1/2019								
DESIGN STANDARDS ENGINEER	DATE								
	6/5/2019								
CHIEF ENGINEER	DATE								

NOTES:

1. See Standard Drawing E 610-DRIV-08 for plan of Class VII Drive.
- ② The maximum algebraic difference in grades shall not exceed 8% for crested grades and 12% for sagged grade.
- ③ See Standard Drawing E 610-DRIV-14 for joint placement, monolithic curb, and concrete curb and gutter details.

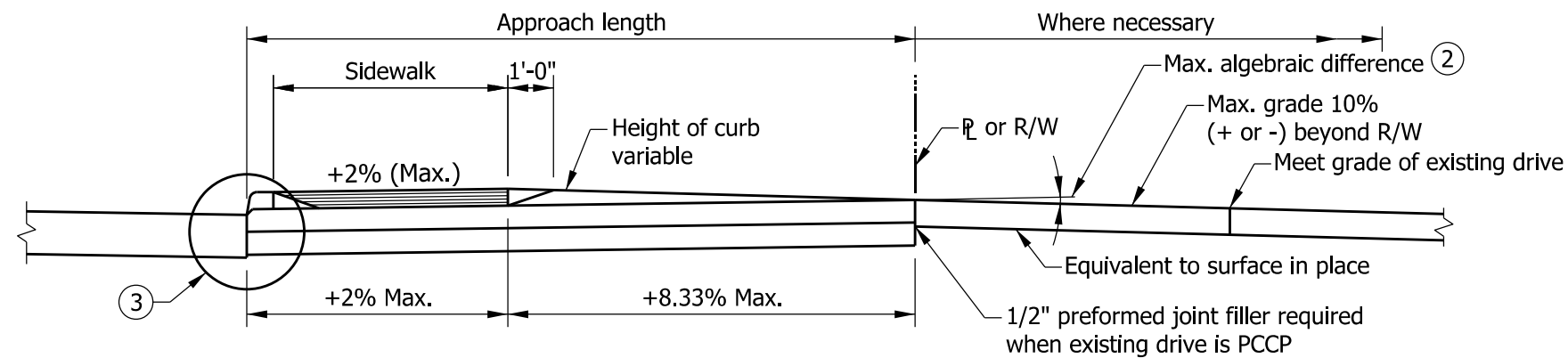

SECTION A-A

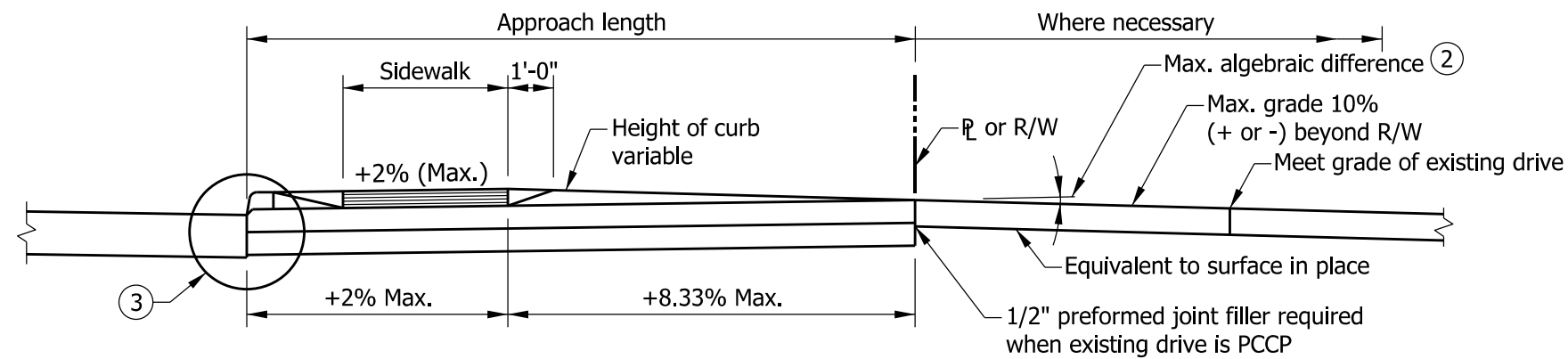

SECTION B-B

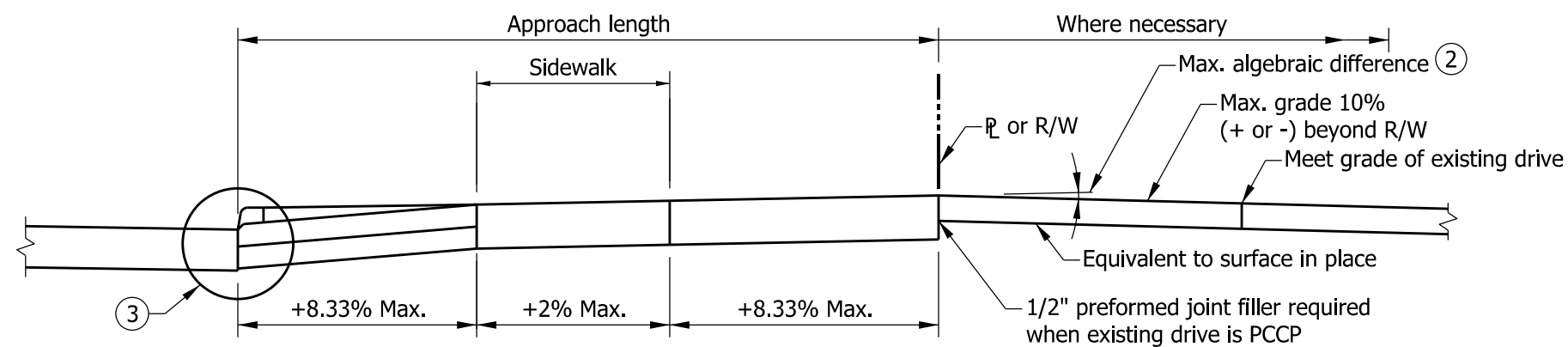

SECTION C-C

LEGEND

▬▬▬ = Curb Ramp or Sidewalk Elevation Transition



INDIANA DEPARTMENT OF TRANSPORTATION

CLASS VII DRIVE
APPROACH GRADES

SEPTEMBER 2019

STANDARD DRAWING NO. E 610-DRIV-13



	5/1/2019
DESIGN STANDARDS ENGINEER	DATE
	6/5/2019
CHIEF ENGINEER	DATE

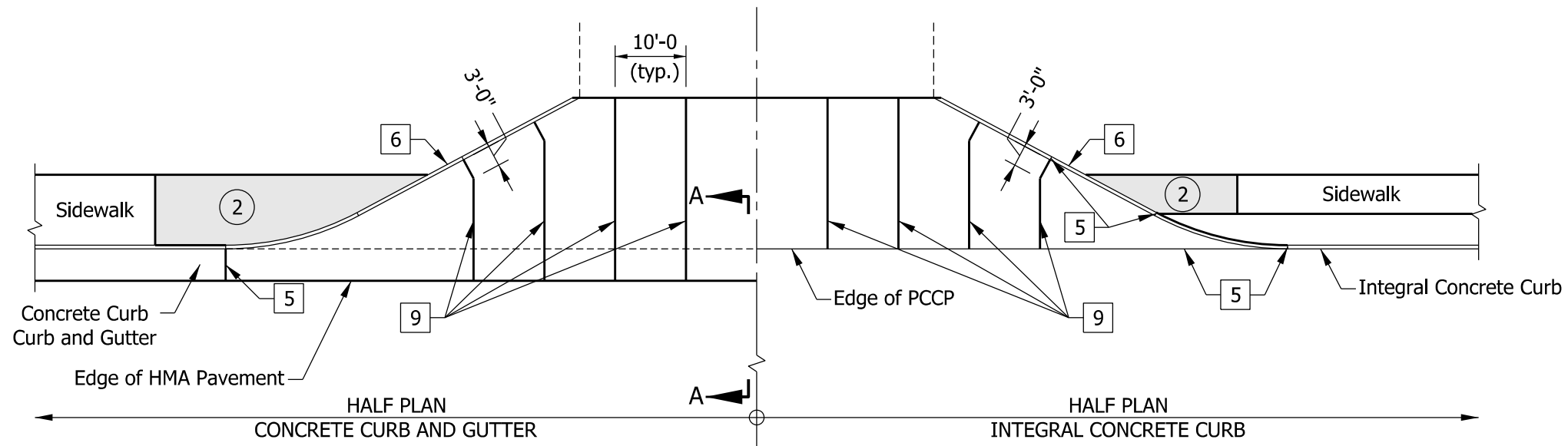

JOINT PLACEMENT DETAIL FOR PCCP DRIVES

NOTES:

1. See Standard Drawing series E 503-CCPJ for joint details.
- ② See Standard Drawing E 604-SDWK-03 sidewalk driveway crossing details.

LEGEND

- 5 1/2" Preformed Joint Filler
- 6 Monolithic Curb
- 9 Longitudinal Joint

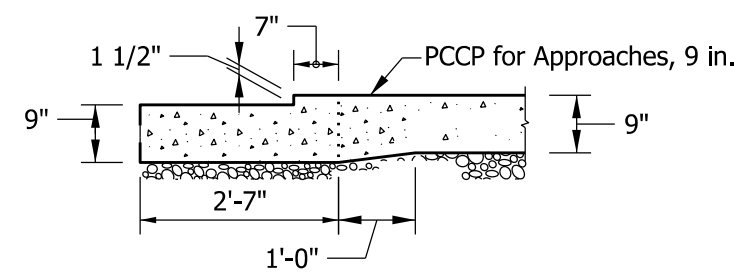

CLASS III AND CLASS VII DRIVE CONCRETE CURB AND GUTTER DETAIL

SECTION A-A

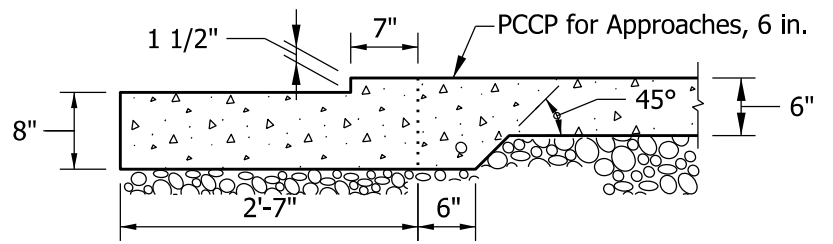

CLASS I DRIVE CONCRETE CURB AND GUTTER DETAIL

SECTION A-A

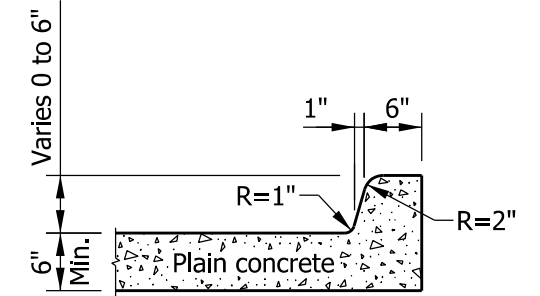

MONOLITHIC CURB

6

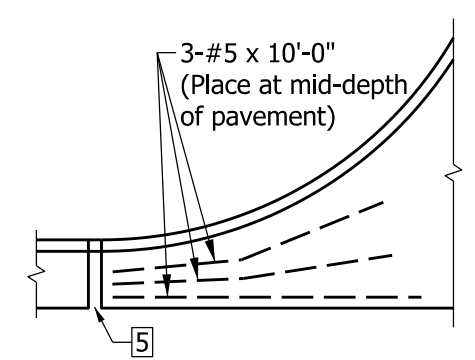

CONCRETE CURB AND GUTTER

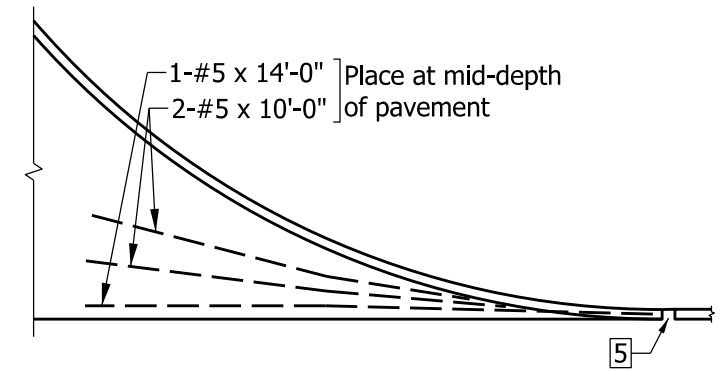

INTEGRAL CONCRETE CURB

TYPICAL CORNER REINFORCING FOR CLASS I DRIVE

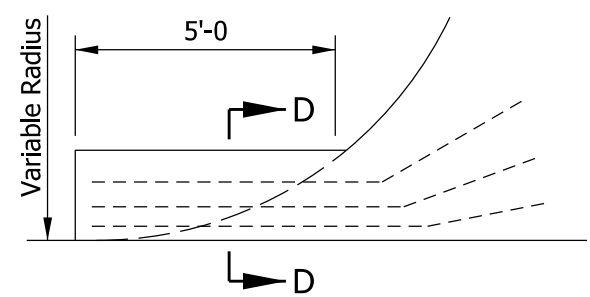

TYPICAL CORNER REINFORCING FOR CLASS II DRIVE

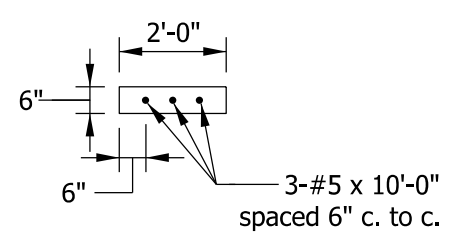

SECTION D-D

INDIANA DEPARTMENT OF TRANSPORTATION	
JOINT PLACEMENT, CORNER REINFORCING, MONOLITHIC CURB, AND CONCRETE CURB AND GUTTER DETAILS	
SEPTEMBER 2019	
STANDARD DRAWING NO.	E 610-DRIV-14
	 DESIGN STANDARDS ENGINEER DATE 5/29/2019
 CHIEF ENGINEER	DATE 6/5/2019

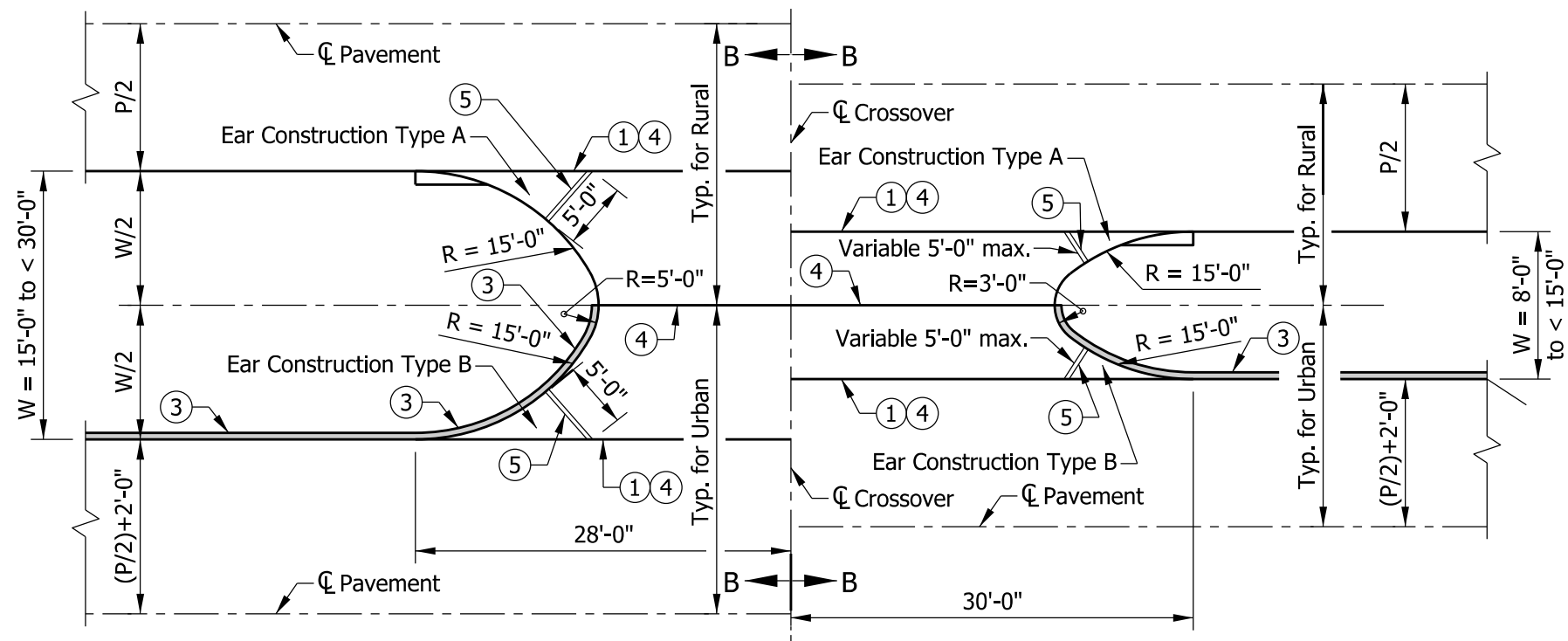

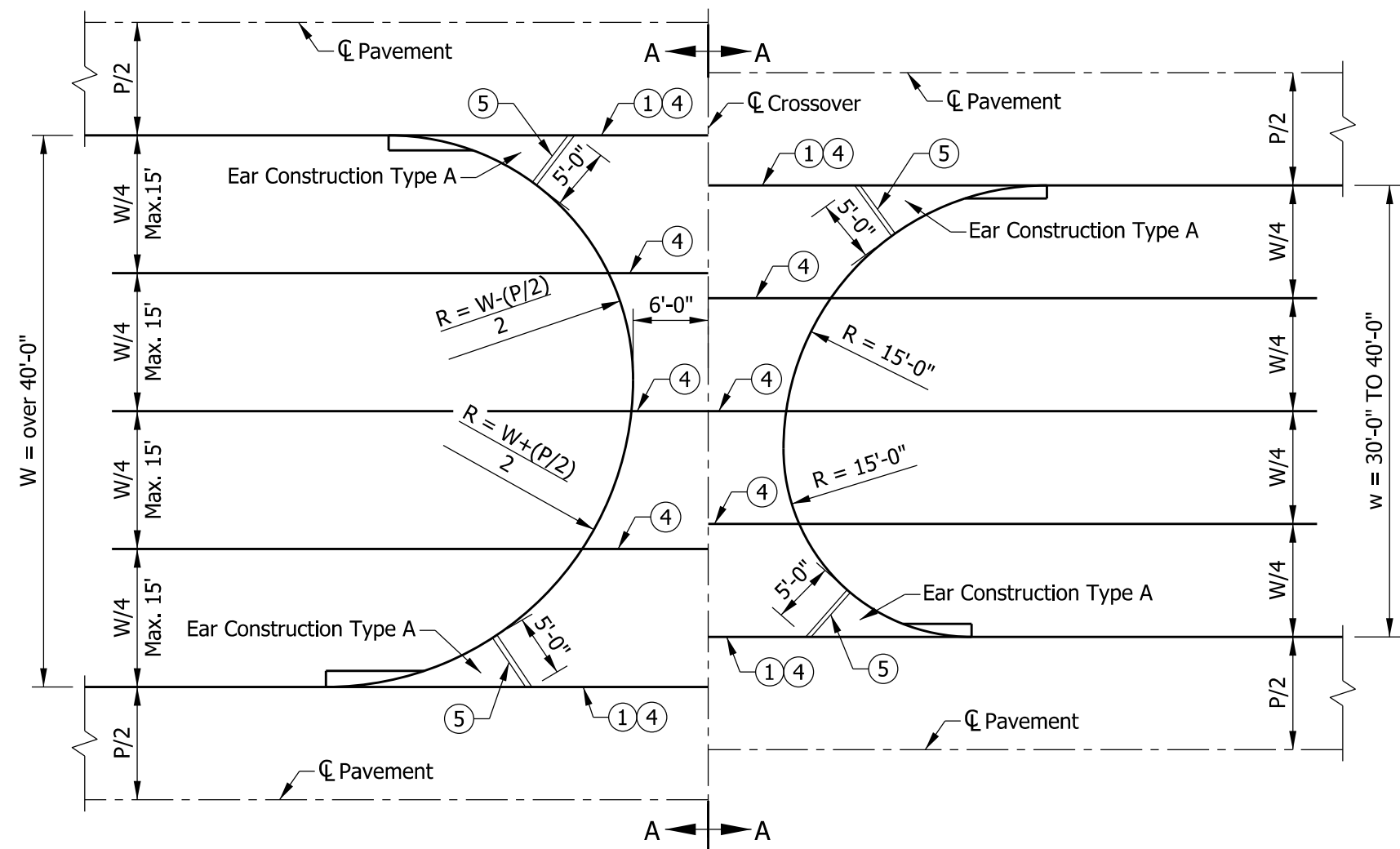

PRIVATE DRIVE CROSSOVER PLAN FOR W = 8'-0" to less than 30'-0"



PRIVATE DRIVE CROSSOVER PLAN FOR W = 30'-0" to over 40'-0"

NOTES:

- ① Thickened edge
2. See Standard Drawings:
E 605-ERCN-01 for Ear Construction Type "A" and Type "B" details.
E 610-DRIV-16 for sections A-A and B-B
- ③ See Standard Drawing E 605-CCIN-01 for Integral Concrete Curb details.
- ④ Longitudinal Joint, see Standard Drawing series E 503-CCPJ for joint details.
- ⑤ 1" Preformed Joint Filler.
6. See Standard Drawing E 610-DRIV-16 for sections A-A and B-B for PCCP and HMA pavement.

INDIANA DEPARTMENT OF TRANSPORTATION	
PRIVATE DRIVE CROSSOVER PLANS	
SEPTEMBER 2019	
STANDARD DRAWING NO.	E 610-DRIV-15
	<div style="display: flex; justify-content: space-between;"> <div style="text-align: center;">  DESIGN STANDARDS ENGINEER </div> <div style="text-align: center;"> 5/1/2019 DATE </div> </div> <div style="display: flex; justify-content: space-between; margin-top: 10px;"> <div style="text-align: center;">  CHIEF ENGINEER </div> <div style="text-align: center;"> 6/5/2019 DATE </div> </div>

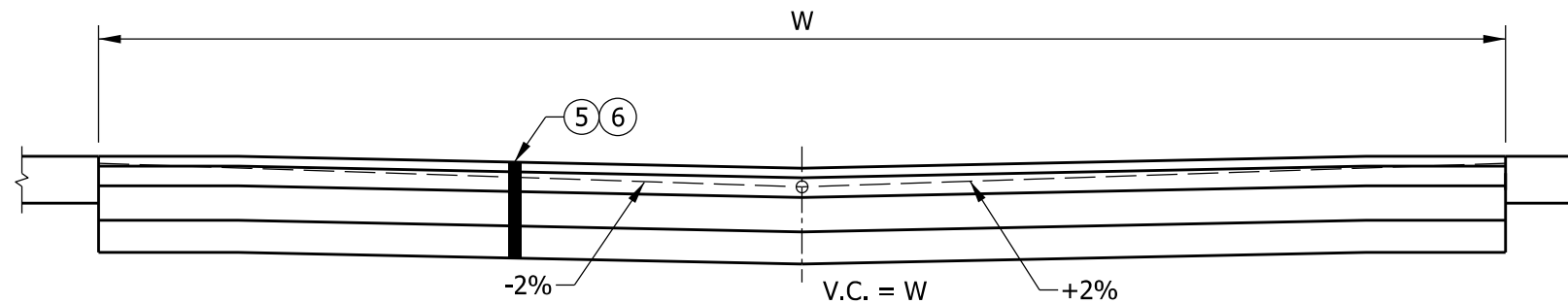
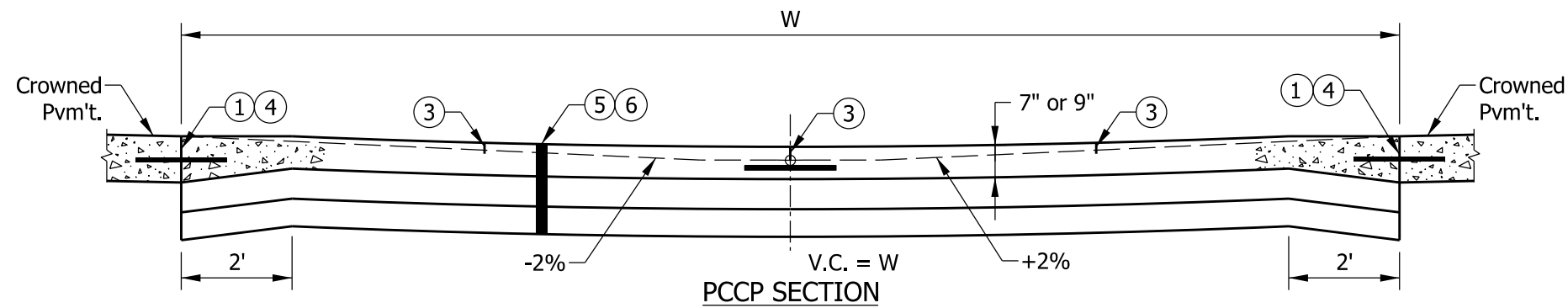

HMA SECTION
SECTION A-A
SECTION TO BE USED WITH CROWN PAVEMENT

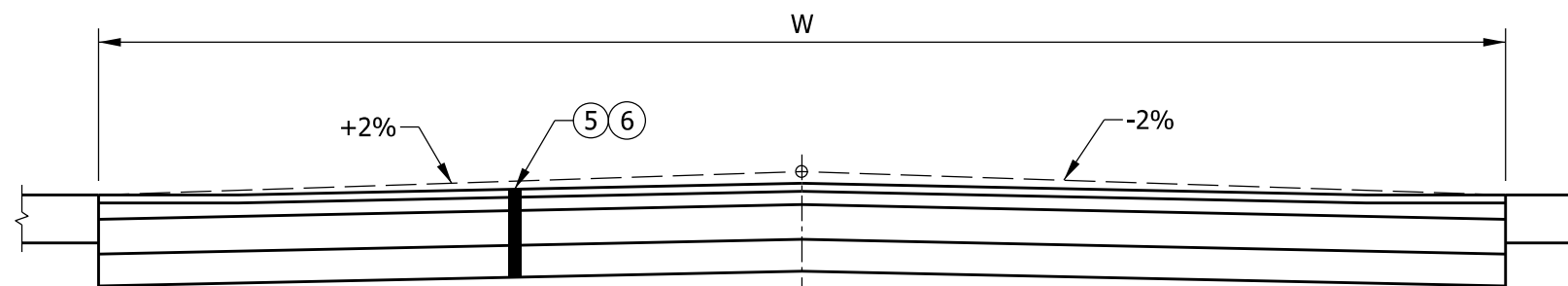
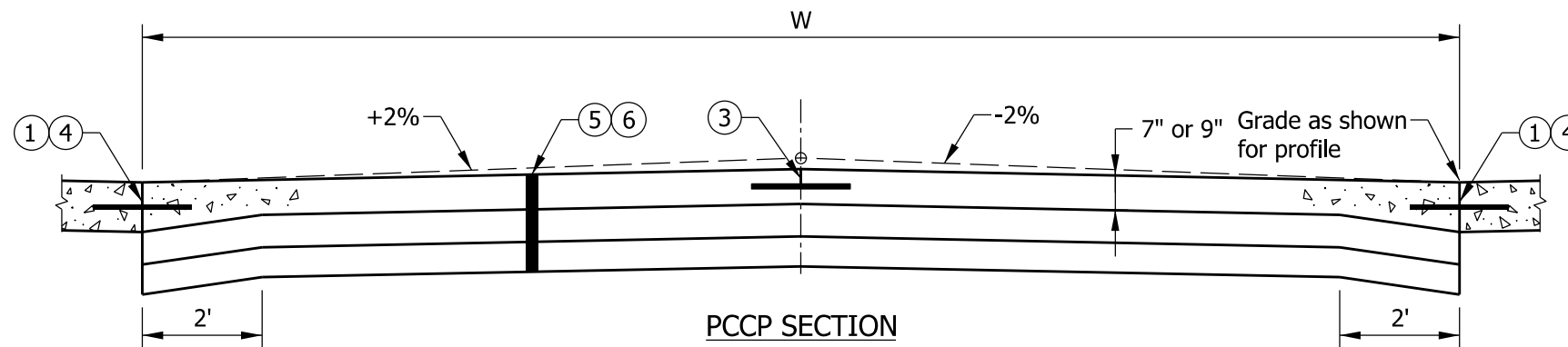

HMA SECTION
SECTION B-B
SECTION TO BE USED WITH 3-IN. TILTED PAVEMENT

NOTES:

- ① Thickened edge to be same thickness as mainline pavement.
2. See Standard Drawings E 610-DRIV-15 and E 610-DRIV-17 for location of Sections A-A and B-B.
- ③ Contraction Joint Type D-1. See Standard Drawing series E 503-CCPJ for details, and Standard Drawing E 610-DRIV-14 for spacing.
- ④ Longitudinal Joint, see Standard Drawing series E 503-CCPJ for joint details.
- ⑤ Private Drive Crossover shall be constructed of HMA or PCCP as shown on the plans, unless otherwise directed.
For AADTT ≤ 50
HMA for Approaches, Type B:
165 lbs/yd² HMA Surface Type B on
275 lbs/yd² HMA Intermediate, Type B on
6" Compacted Aggregate, No. 53 on
Subgrade Treatment, Type II (6 in. Coarse Aggregate, No. 53)
or
PCCP for Approaches, 7 in. on
Dense Graded Subbase, 6 in., on
Subgrade Treatment Type II (6 in. Coarse Aggregate, No. 53)
- ⑥ Commercial Drive Crossover shall be constructed of HMA or PCCP as shown on the plans, unless otherwise directed.
For AADTT ≤ 50
HMA for Approaches, Type B:
165 lbs/yd² HMA Surface Type B on
275 lbs/yd² HMA Intermediate, Type B on
6" Compacted Aggregate, No. 53 on
Subgrade Treatment, Type II (6 in. Coarse Aggregate, No. 53)
or
PCCP for Approaches, 9 in. on
Dense Graded Subbase, 6 in., on
Subgrade Treatment Type II (6 in. Coarse Aggregate, No. 53)



INDIANA DEPARTMENT OF TRANSPORTATION

PRIVATE AND COMMERCIAL DRIVE
CROSSOVER SECTIONS

SEPTEMBER 2019

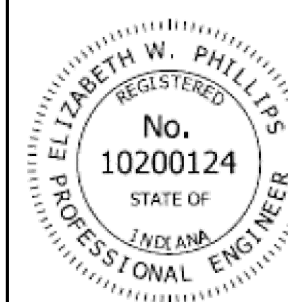
STANDARD DRAWING NO. E 610-DRIV-16



	5/1/2019
DESIGN STANDARDS ENGINEER	DATE
	6/5/2019
CHIEF ENGINEER	DATE

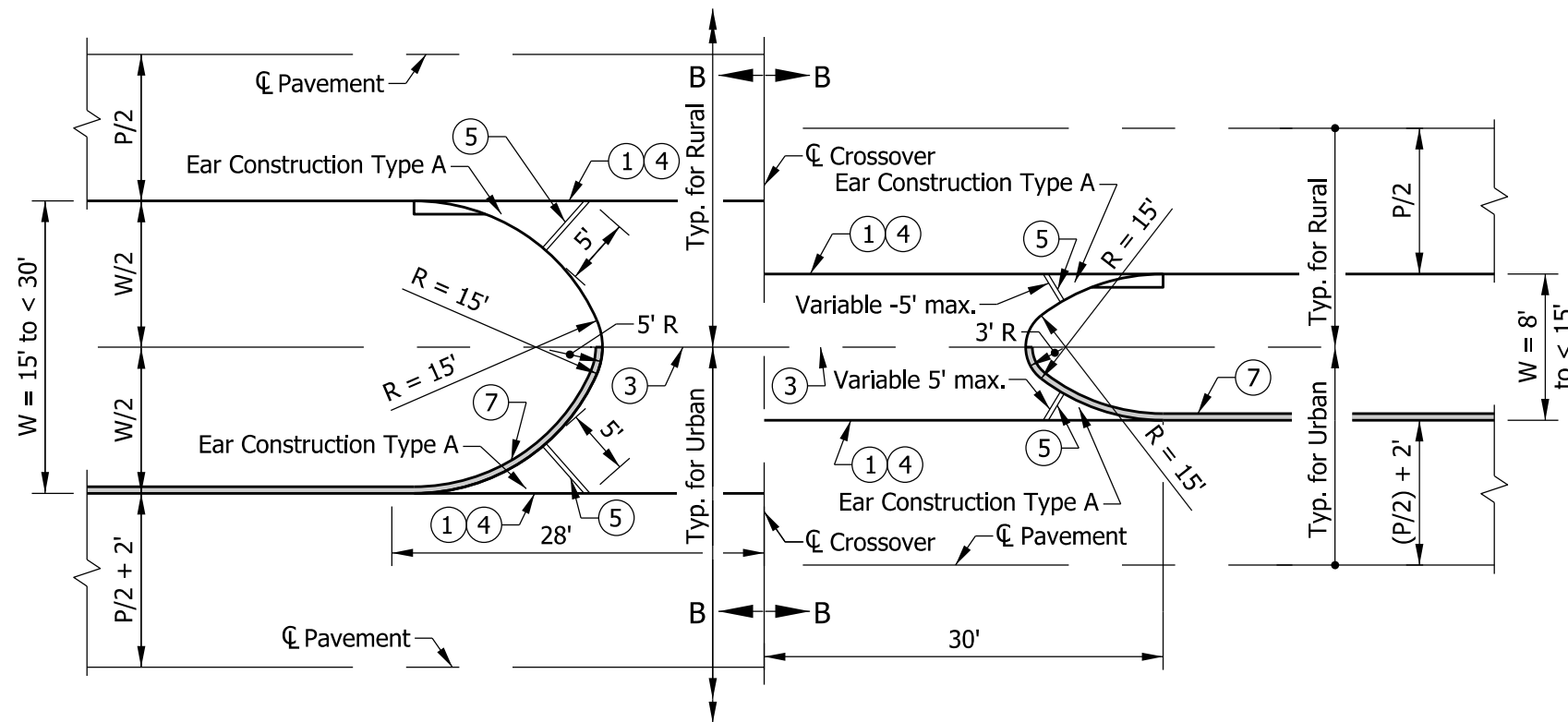

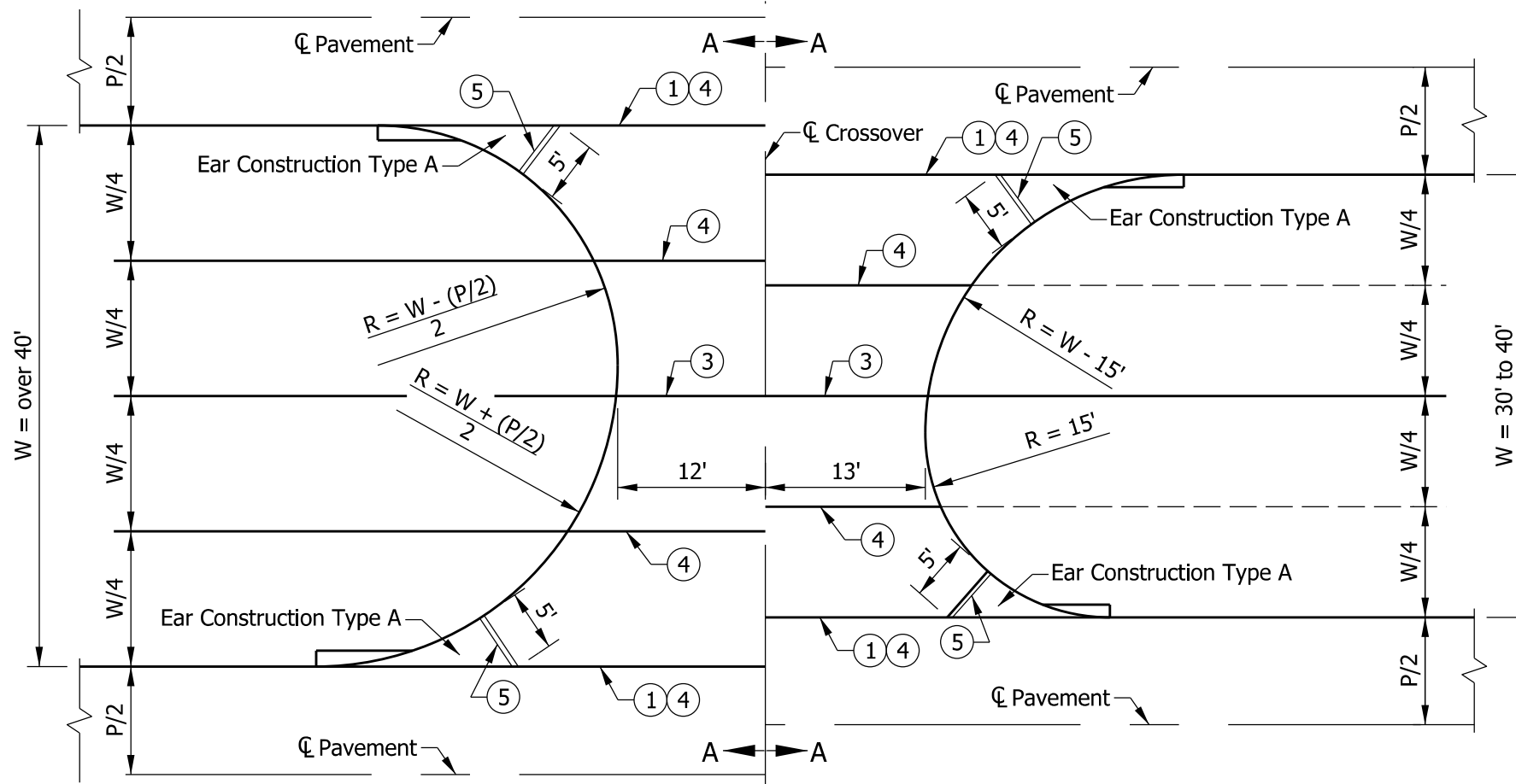

COMMERCIAL DRIVE CROSSOVER PLAN FOR W = 8' to less than 30'



COMMERCIAL DRIVE CROSSOVER PLAN FOR W = 30' to over 40'

NOTES:

- ① Thickened edge
2. See Standard Drawings E 605-ERCN-01 for Ear Construction for Type "A" and Type "B" details.
- ③ Contraction Joint, Type D-1, see Standard Drawing series E 503-CCPJ for joint details.
- ④ Longitudinal joint, see Standard Drawing series E 503-CCPJ for joint details.
- ⑤ 1" Preformed Joint Filler.
6. Grades for the commercial drive crossover shall be the same as for private drive crossover. See Standard Drawing E 610-DRIV-16 for sections A-A and B-B for PCCP and HMA pavement.
- ⑦ See Standard Drawing E 605-CCIN-01 for Integral Concrete Curb details.

INDIANA DEPARTMENT OF TRANSPORTATION	
COMMERCIAL DRIVE CROSSOVER PLANS	
SEPTEMBER 2019	
STANDARD DRAWING NO.	E 610-DRIV-17
	 DESIGN STANDARDS ENGINEER 5/1/2019 DATE
 CHIEF ENGINEER	6/5/2019 DATE

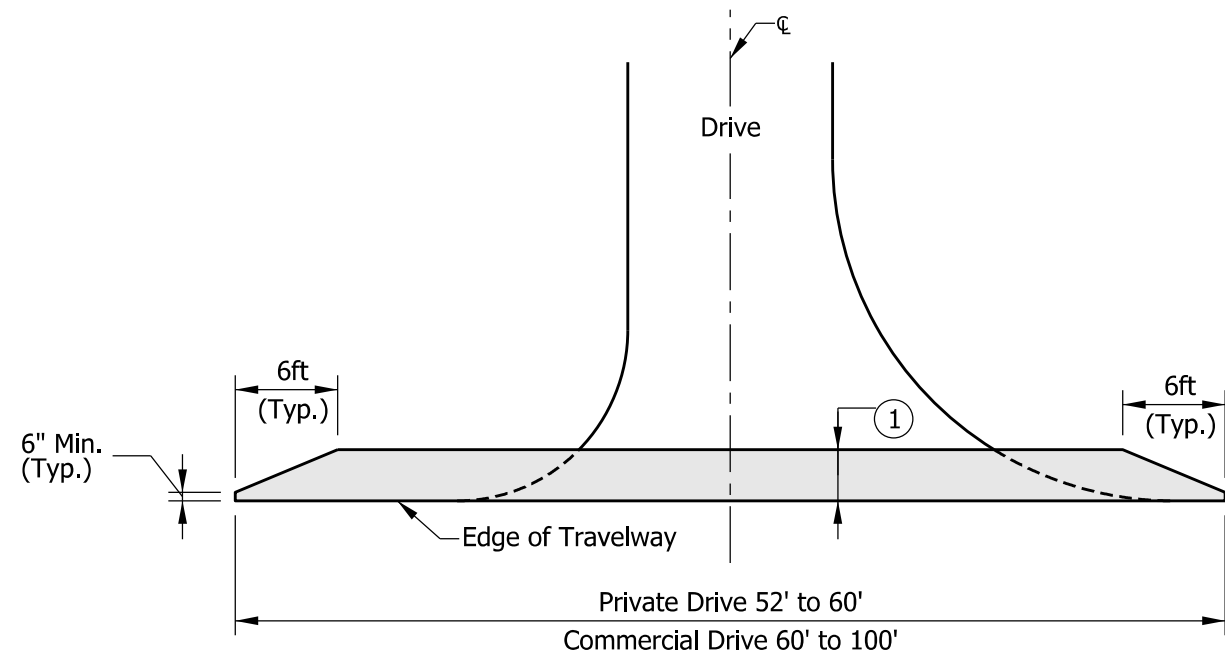

PAVEMENT WEDGE PLAN VIEW

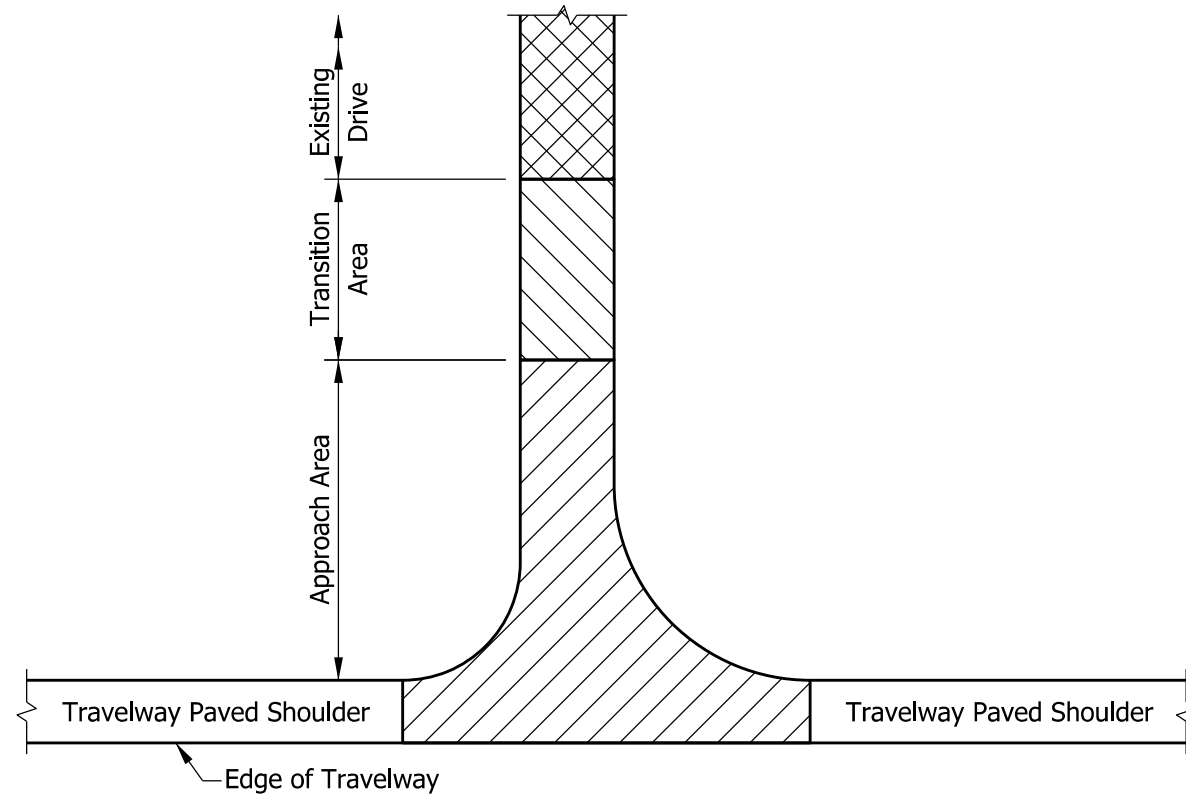

PAY LIMITS FOR CLASS II, IV, AND VI DRIVES

NOTES:

- ① 3 ft or wider as necessary to feather to existing grade.
2. Pavement wedge to be centered on centerline of drive.
3. The pay limits shown herein generally apply to Class II, IV, and VI Drives.
4. Approach Area - HMA for Approaches or PCCP for Approaches. This area typically extends from the edge of an 8 foot or wider paved travelway shoulder to the right of way or property line or within a few feet of the right of way or property line where the new drive meets the grade of the existing drive, depending on the site-specific conditions. Where the travelway paved shoulder width is less than 8 feet, this area will be measured from the edge of travelway.
5. Transition Area - an equivalent pavement section to the existing drive. This area typically extends from the right of way or property line to a point on the property owner's drive where the new drive grade can match the existing drive grade.

LEGEND

Drive area to be treated with HMA for Approaches

INDIANA DEPARTMENT OF TRANSPORTATION	
PAVEMENT WEDGE AND PAY LIMITS FOR CLASS II, IV, AND VI DRIVES	
SEPTEMBER 2019	
STANDARD DRAWING NO.	E 610-DRIV-18
	<div style="text-align: right; margin-bottom: 10px;"> 5/29/2019 DESIGN STANDARDS ENGINEER DATE </div> <div style="text-align: right;"> 6/5/2019 CHIEF ENGINEER DATE </div>